

like

Da più di 50 anni, lo Scaldacqua Ita

# GENERAL CATALOGUE

Water Heaters  
Indirect Cylinders  
Inertial Puffers  
Heat Pumps





Quality with Tradition

## For over 50 years The Italian Water Heater.

### THE RANGE

Quality, safe, practical, durable and reliable.

- Electric water heaters
- Gas-fired water heater
- Wood-fired water heater
- Glass-lined indirect cylinders
- Stainless steel indirect cylinders
- Tank in Tank
- Inertial Puffers
- Heat Pumps

### Capacity

- From 10 to over 2000 litres

### USE

- For domestic use
- For collective use
- For industry

*Enter the LIKE world  
On [likeonline.it](http://likeonline.it)*

Today, after more than 50 years, the LIKE trademark still stands for the best quality products for production of sanitary hot water in Italy.

From the very beginning, the brand name LIKE was synonymous with Water Heaters manufactured in accordance with high levels of reliability and safety; with the passing of years LIKE has succeeded in winning the esteem and approval of professionals in the sector, with products that ensure exceptional performance through the quality, safety, practicality and durability of the product.

Thanks to innovative technologies applied in LIKE factories, the company produces models whose *performance is unique on the market*, characterised by a simple and elegant design, ideal also for visible installations in the kitchen or bathroom environment.

**Today the LIKE trademark is a reference point for all professionals in the thermal-hydraulic sector who recognize in its products a high level of technology geared to domestic comfort.**

LIKE designs and directly manufactures all the key elements of the boiler.

To guarantee total reliability, all LIKE products are assembled and inspected individually before leaving the factory floor.

LIKE builds products which are technically advanced, produced with quality materials made to last and bring comfort and convenience into homes throughout the world. For apartments or houses, individual or centralized systems everywhere offer one the possibility of a safe choice.

LIKE boilers are likewise devised with a view to minimum encumbrance and to ensure the lowest possible levels of consumption, to help safeguard the environment.

**The LIKE catalogue, with a vast range of models and capacities, allowing you to choose the product most in keeping with your needs, always ensuring maximum comfort.**

Within the wide choice of LIKE models, you will find the model that fills your own needs. Wide choice of technical features, capacities and dimensions, all conforming to the strictest standards of construction, protective of the environment and attentive to the energy saving.

























In the last few years, Like's position has been growing until becoming one of the main players of the sector. Its growth derives from strategic choices, continuous research and customer care: in a few words, passion for its own job.

Thus, on December 27th, 2007 the company changed its name into Gruppo Giona SpA.

This transformation supplies an increased guarantee for our customers, partners and suppliers. A new energy that strengthens our constant commitment in research, quality, professionalism and services.

## Key

To permit identification of the main features of your LIKE Water Heater.

LIKE DIAMOND Glass-lined Flow Coating	
LIKE RAPIDO	
FLANGE OF BROAD DIAMETER Easy inspection and swift maintenance	
LIKE Anti-corrosion	
SHIELDED heating element	
Thermostat	
Energy Saving	
Light Indicator	
STAINLESS STEEL Elements	INOX
NYLON dielectric elements, high-resistance	NYLON
Anti-corrosion device Smart CORREX	
LIKE EASY Quick assembly	
PIEZOELECTRIC ignition	
DOMESTIC use	
INDUSTRIAL and COMMUNITY application	
Fan	
Electronic	
CFC HCFC free	
Double coil	
Reversible	
High efficiency	
Temperature adjustment	
TRIPLUS safety GAS system	
Electric Integration	
	

# CONTENTS

**ELECTRIC  
WATER HEATERS** 2



**WOOD-FIRED  
WATER HEATERS** 18



**GAS  
WATER HEATERS** 20



**INDIRECT  
CYLINDERS** 28



**INERTIAL  
PUFFERS** 49



**TANK in TANK** 52



**HEAT PUMPS** 54

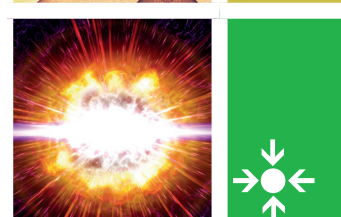



# ELECTRIC WATER HEATERS

## DOMESTIC USE

RAPIDI  
CLOCK  
STANDARD  
ENERGY  
INOX

## INDUSTRIAL AND COLLECTIVE USE

HIGH INDUSTRIAL  
CAPACITY HEATERS  
INDUSTRIAL  
STAINLESS STEEL

## THE RANGE

Quality, safety, practicality, durability and reliability.

Con With its range of electric storage water heaters, LIKE offers a complete panorama of solutions for generation of hot water with water content between 10 and 500 litres and power between 1,2 and 10 kW with single and three-phase connections.

This range responds to domestic needs in addition to being suitable for industrial and collective use.

The product line ranges from 'rapid' models ideal for fast and economic generation of small quantities of water, to the 'clock' model which is a small-sized water heater devised for installations which are problematic from the viewpoint of space, to the classical 'standard' model consisting of the standard range geared to respond to essential market requirements, and finally to the 'Energy' line which, with its higher number of combinations, satisfies the highest expectations for quality, in keeping with European and international rules.



## LIKE INOX

The latest INOX line embraces the philosophy of total quality and advanced construction technology. The result is a line of products without compromise, designed to last and to yield the maximum, from the first day of installation.

**AISI 316L STAINLESS STEEL**  
Superior quality stainless steel.

**SPECIAL TIG and PLASMA WELDING**

Guarantees the same resistance also in junction points.

### MAGNESIUM ANODE

LIKE mounts only Magnesium Anodes in its water heaters, which effectively combat the natural process of corrosion.

## THERMAL INSULATION

LIKE has selected only high-density Polyurethane (PU) offered in three insulation configurations. Standard / Medium / HiGrade.

PU guarantees exceptional thermal insulation, reduced power consumption and optimal performance.

## LIKE DIAMOND

DIAMOND is the opal glazing and enamelling process known as glass-lined "Flow Coating". 850°C for guaranteed quality internal protection.

DIAMOND protects your boiler and prevents corrosion, thereby guaranteeing a continually efficient product.

## ACTIVE ANTI-CORROSION PROTECTION CORREX®

CORREX is the revolutionary system of corrosion control. CORREX is a smart electronic system which actively and continually protects your boiler. Comes with Titanium Anode and a visual control

system. CORREX is the definitive remedy against the build-up of limescale.

Ensuring a working life and performance which is without parallel.

## LIKE EASY CHECK

External regulation (optional) ultimately allows easy and quick regulation of the temperature of the water heater. LIKE has carried out studies of broad diameter flanges to allow easy inspection, cleaning and maintenance of internal components.

## DOUBLE SAFETY

LIKE water heaters offer the highest levels of protection and safety.

Double safety with thermostats independent of functioning and overtemperature.

Level of protection IP in conformity with the strictest international rules, which makes LIKE water heaters safe even in hazardous conditions.



# ERX *inox*

ELECTRIC WATER HEATERS  
ABOVE-SINK AND UNDER-SINK  
LT 10



## Compactness and velocity without parallel



“ERX inox” wall-mounted electric storage water heaters are designed for producing small quantities of water in a rapid and cheap way, as well as to meet the new expectations as to durability and perfection.

The “inox” stainless steel product line has been created for this purpose; this line supplies maximum quality and durability thanks to the use of special materials, such as stainless steel and sophisticated technological solutions, such as “TIG” and “Microplasma” welding.

They can be installed above and under the sink.

AISI 316L stainless steel boiler, welded with “TIG” and “Microplasma” technology.

AISI 321 stainless steel heating element.

Stem safety and adjustment thermostat.

Insulation layer with polystyrene (EPS) shells to minimise heat loss.

Shell and back made with shock-resistant polypropylene (PP).

Wall-mount by using the specific brackets.

Indicator light.

IPX5 protective cover over electrical parts.

Nylon dielectric circuit breakers on the hydraulic fittings.

ABOVE-SINK ERX (mm)

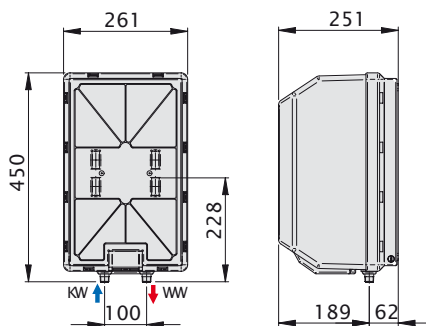

UNDER-SINK ERSX (mm)

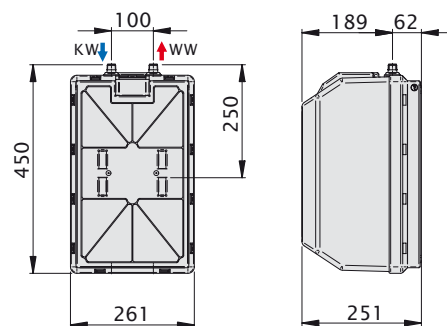

	Capacity	Power	Voltage	Heating time $\Delta t=50^{\circ}\text{C}$	Max operating temperature	Max operating press.	Net weight	Hydraulic connections
	l	kW	V~	min	$^{\circ}\text{C}$	Mpa	kg	KW-WW
ERX 512	10	1,2	230	30	75	0,8	4,6	R ½"
ERSX 512	10	1,2	230	30	75	0,8	4,6	R ½"

LIKE ELECTRIC WATER HEATERS / For Domestic Use



# ER-ERS

ELECTRIC WATER HEATERS  
ABOVE-SINK AND UNDER-SINK  
LT 10 15

## Compactness and velocity without parallel

Attention to detail, well proportioned and very compact, they are easily and quickly installed, making full use of small spaces.

THE IDEAL PRODUCT when hot water is required quickly, with frequent withdrawals of moderate size.

Models equipped with external regulation ER Above-sink and ERS Below-sink.

Steel tank, manufactured in heavy gauge steel plate, is glass-lined using the flowcoating

method (850 °C).

Integrated magnesium Anode.

1/2" connections, center-to-center 100 mm are standard with the majority of appliances already in existence, and permit fast installing even in installations to be renewed.

The cold water intake pipe is equipped with a diffuser head in removable nylon.

The hot water outlet pipe in stainless steel, extractable to permit cleaning of limescale deposits.

Iron-plated curved electric heating element regulated by bi-polar thermostat. An indicator light indicates if the appliance is on.

Temperature regulation. In the model with external thermostat the temperature of the hot water supplied may be easily selected by operating the external knob on the control panel. The "N" models are not externally adjustable.

Insulation in pre-moulded shells of high density insulation material: thermal insulation and energy saving.

Safety. Equipped with a rapid bipolar internal safety thermostat which intervenes where there is an abnormal rise in temperature. Indicator light signals correct functioning.



ABOVE-SINK ER (mm)

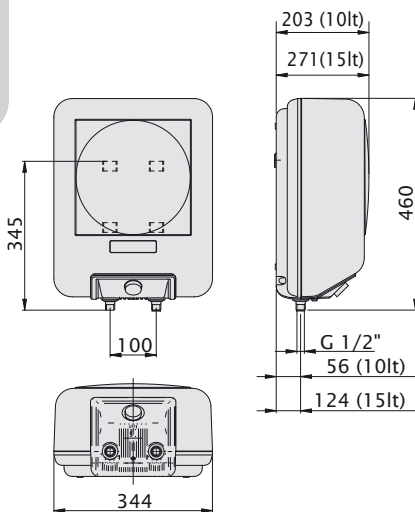

UNDER-SINK ERS (mm)

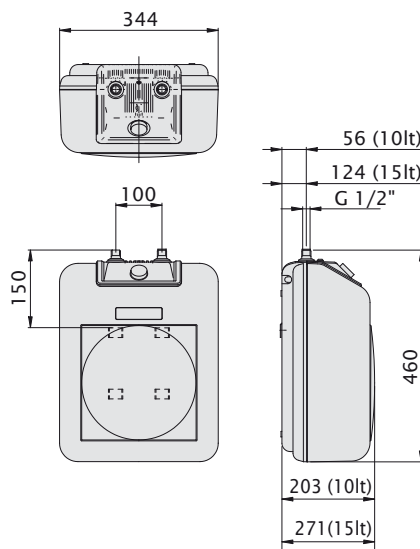

	Capacity	Power	Voltage	Heating time $\Delta t=50^{\circ}\text{C}$	Max operating temperature	Max operating press.	Net weight	Hydraulic connections
	l	kW	V~	min	$^{\circ}\text{C}$	Mpa	kg	KW-WW
ER 10 N	10	1,5	230	41	75	0,8	6,5	R 1/2"
ERS 10 N	10	1,5	230	41	75	0,8	6,5	R 1/2"
ER 10	10	1,5	230	41	75	0,8	6,5	R 1/2"
ERS 10	10	1,5	230	41	75	0,8	6,5	R 1/2"
ER 15 N	15	1,5	230	61	75	0,8	7,6	R 1/2"
ERS 15 N	15	1,5	230	61	75	0,8	7,6	R 1/2"
ER 15	15	1,5	230	61	75	0,8	7,6	R 1/2"
ERS 15	15	1,5	230	61	75	0,8	7,6	R 1/2"



# CK-CLOCK

ELECTRIC  
WATER HEATERS  
LT 25



## Circular design, multipurpose



Water heater that is easy to install thanks to smaller sizes.

Circular design.

Beins very neat, proportioned and very compact, it is easy to install and is easily adaptable to making the most of small spaces.

It is particularly suitable when hot water is required quickly with frequent withdrawals of modest size.

Steel tank, glass-lined using the flowcoating method (850 °C) model CKR 525 with external regulation.

Electric unit of 1200 W.

Insulation in foam polyurethane.

Anti-corrosion anode of magnesium.

External varnish produced with epoxide powders.

Safety valve adjusted to 8 bar.

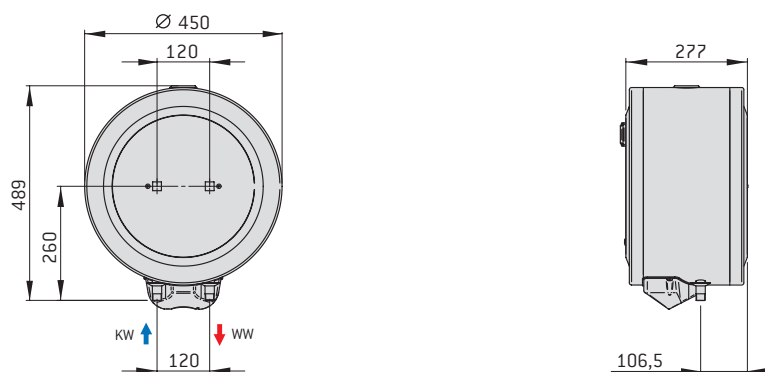

	Capacity	Power	Voltage	Heating time $\Delta t=50^{\circ}\text{C}$	Max operating temperature	Max operating press.	Net weight	Hydraulic connections
	l	kW	V~	min	$^{\circ}\text{C}$	Mpa	kg	KW - WW
CLOCK	25	1,2	230	77	75	0,8	12	R 1/2"

LIKE ELECTRIC WATER HEATERS / For Domestic Use



# EXS inox

## ELECTRIC WATER HEATERS LT 65

LIKE ELECTRIC WATER HEATERS / For Domestic Use



### Compactness and velocity without parallel

The "EXS inox" wall-mounted electric storage water heater represents the basic range that combines great functionality, high efficiency and maximum quality.

AISI 316L stainless steel boiler, welded with "TIG" and "Microplasma" technology.

Corrosion-proof magnesium anode.

AISI 321 stainless steel threaded heating element on 1" sleeve.

Capillary safety and internal regulation thermostat.

Indicator light.

CFC and HCFC-free, very thick expanded polyurethane (PU) insulation layer.

External casing made of sheet metal coated with epoxy powder paint.

IPX5 protective cover over electrical parts.

Stored water temperature indicator.

Nylon dielectric circuit breakers on the hydraulic fittings.

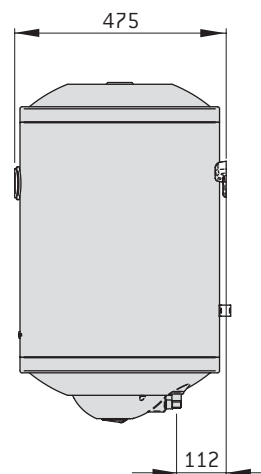
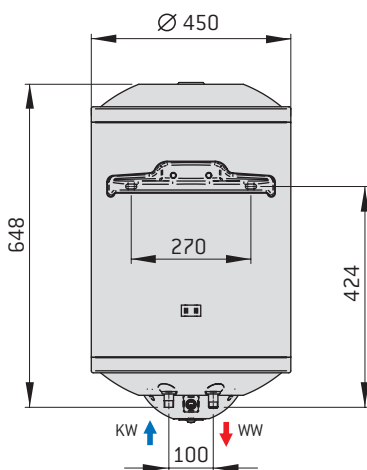

	Capacity	Power	Voltage	Heating time $\Delta t=50^{\circ}\text{C}$	Insul. thickness	Max operating temperature	Max operating press.	Net weight	Hydraulic connections
	l	kW	V~	min	mm	$^{\circ}\text{C}$	Mpa	kg	KW-WW
EXS 65	65	1,2	230	198	$\geq 25$	75	0,8	15,50	R 1/2



**EX** *inox*

ELECTRIC  
WATER HEATERS  
LT 50 80 100



**INOX, the highest quality**



“EXTRA INOX” stainless steel wall-hung electric storage water heaters are designed to meet the new expectations as to durability and perfection.

To this end, the “inox” (stainless steel) product line was introduced, providing maximum quality and durability owing to the use of special materials such as stainless steel and sophisticated technological solutions such as “TIG” and “Microplasma” welding.

Aisi 316L stainless steel tank welded with “TIG” and “Microplasma” technology.

Tank inspection flange.

“Correx®” electronic protection device with titanium anode and signalling LED.

Incoloy 800 stainless steel heating element fitted on a flange.

External regulation and safety capillary thermostat.

LED indicator light.

CFC and HCFC-free very thick polyurethane (PU) foam insulation layer.

External casing made of sheet metal coated with epoxy powder paint.

IPX5 protective cover over electrical parts complete with cable and plug.

Stored water temperature indicator.

Nylon dielectric circuit breakers on the hydraulic fittings.

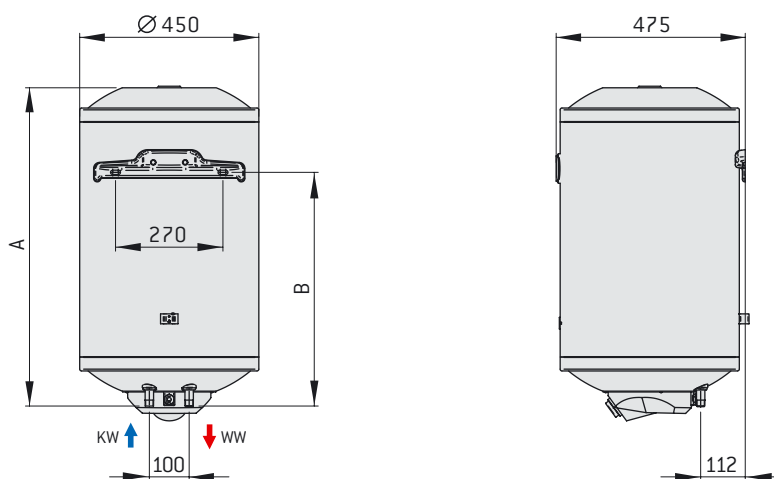

	Capacity	Power	Voltage	Heating time $\Delta t=50\text{ C}$	Insul. thickness	Heat loss 65 C	Max operating temp.	Max operating press.	Net weight	Hydraulic connections	A	B
	l	kw	V~	min	mm	kWh/24h	°C	Mpa	kg	KW-WW	mm	mm
EX 50	50	1,5	230	123	≥25	0,87	75	0,8	14,0	R ½	596	375
EX 80	80	1,5	230	196	≥25	1,13	75	0,8	18,5	R ½	799	587
EX 100	100	1,5	230	245	≥25	1,30	75	0,8	23,5	R ½	1013	801

LIKE ELECTRIC WATER HEATERS / For Domestic Use



# EV-EV/T EO-EO/T

ELECTRIC  
WATER HEATERS  
LT 30 50 80 100

LIKE ELECTRIC WATER HEATERS / For Domestic Use



The new LIKE line of electrically heated storage water heaters, manufactured with innovative technology and with first class materials to guarantee continuing durability and performance.

Tanks: in addition to the increased thickness of the sheet metal used, are glass-lined using the flowcoating method (850 °C).

Magnesium Anode, size varying depending on vessel capacity, for better protection of the boiler from electrochemical corrosion.

Insulation ensured by high-density closed-cell foam polyurethane, eco-friendly due to absence of CFCs damaging to the environment. Ensures minimum heat loss, giving significant energy savings; this makes the appliances more resistant to possible damage in transit.

Electric heating element copper plated, thus facilitating high and fast transmission of heat.

Stainless steel hot water outlet pipe which may be removed to permit cleaning of limescale deposits.

Safety. Bipolar safety thermostat which intervenes where there is an abnormal rise in temperature, and indicator light which signals correct functioning.

Accompanying safety/anti-reflux valve adjusted to 8 bar and pack of dielectric couplers 1/2" MF. The latter offer protection from corrosion from electrolytic action present in the water network.

Thermo-electric water heater model EV/T: Thermo-electric water heaters also belong to this line and are equipped with a coil inside the boiler which, connected to the central network of the heating system like a normal radiator, heats the water contained in the appliance, thus facilitating further energy savings.

Thermal connections on both sides of the vertical appliances, facilitating practical and quick installation.

Horizontal water heaters model EO-EO/T come with left heating element connections.

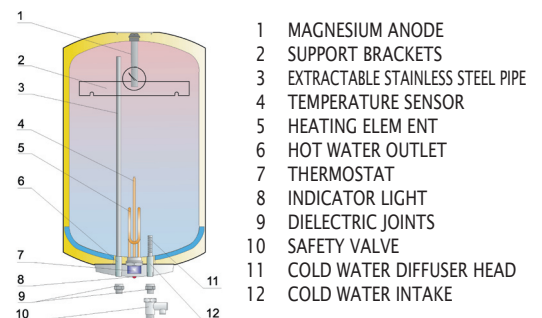
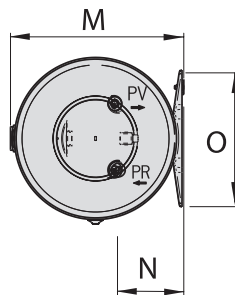
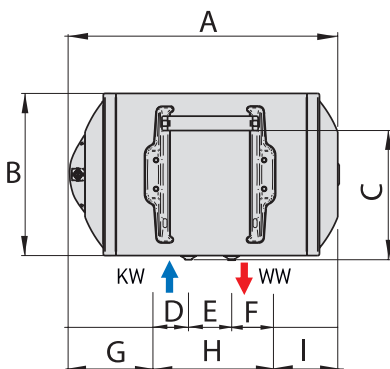
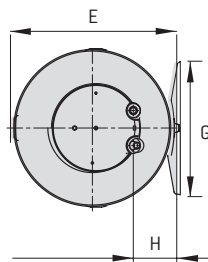
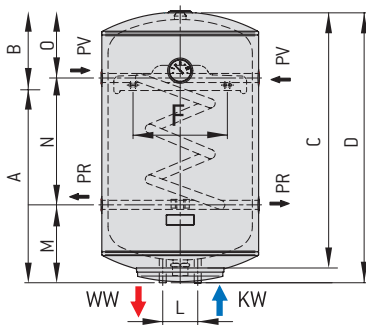



	Capacity	Power	Voltage	Heating time $\Delta t=50^{\circ}\text{C}$	Max operating temp.	Max operating press.	Net weight	Hydraulic connections
	l	kW	V~	min	$^{\circ}\text{C}$	Mpa	kg	KW-WW
EV 30	30	1,2	230	92	75	0,8	12,3	R 1/2"
EV 50	50	1,2	230	153	75	0,8	15,1	R 1/2"
EV 80	80	1,2	230	245	75	0,8	21,8	R 1/2"
EV 100	100	1,2	230	306	75	0,8	25,5	R 1/2"
EO 50	50	1,2	230	153	75	0,8	15,2	R 1/2"
EO 80	80	1,2	230	245	75	0,8	22,0	R 1/2"
EO 100	100	1,2	230	306	75	0,8	25,7	R 1/2"
EV/T 50	50	1,2	230	153	75	0,8	16,5	R 1/2"
EV/T 80	80	1,2	230	245	75	0,8	23,5	R 1/2"
EV/T 100	100	1,2	230	306	75	0,8	27,5	R 1/2"
EO/T 80	80	1,2	230	245	75	0,8	26,5	R 1/2"
EO/T 100	100	1,2	230	306	75	0,8	31,5	R 1/2"

#### SERIES EO - EO/T

	A	B	C	D	E	H	L	M	N	Hydraulic connections	Coil connections
	mm	mm	mm	mm	mm	mm	mm	mm	mm	KW-WW	PV-PR
EO 50	545	450	355	300	120	175	245	480	-	R 1/2"	-
EO 80	780	450	355	345	120	305	245	470	-	R 1/2"	-
EO 100	930	450	355	420	120	456	245	470	-	R 1/2"	-
EO/T 80	755	450	355	345,5	120	250	245	480	200	R 1/2"	Rp 1/2"
EO/T 100	905	450	355	420,5	120	400	245	480	200	R 1/2"	Rp 1/2"

#### SERIES EV - EV/T

	A	B	C	D	E	F	G	H	I	L	M	N	O	Hydraulic connections	Coil connections
	mm	mm	mm	mm	mm	mm	mm	mm	mm	mm	mm	mm	mm	KW-WW	PV-PR
EV 30	345	174	492	519	358	180	285	85	380	100	-	-	-	R 1/2"	-
EV 50	320	230	510	550	450	270	340	124	466	100	-	-	-	R 1/2"	-
EV 80	550	230	740	780	450	270	340	124	466	100	-	-	-	R 1/2"	-
EV100	700	230	890	930	450	270	340	124	466	100	-	-	-	R 1/2"	-
EV/T 50	320	230	510	550	450	270	340	124	466	100	228	132	190	R 1/2"	Rp 1/2"
EV/T 80	550	230	740	780	450	270	340	124	466	100	228	363	189	R 1/2"	Rp 1/2"
EV/T 100	700	230	890	930	450	270	340	124	466	100	228	363	339	R 1/2"	Rp 1/2"



# ENERGY

ELECTRIC  
WATER HEATERS  
LT 40 50 80 100

LIKE ELECTRIC WATER HEATERS / For Domestic Use



## Minimum heat loss, maximum efficiency

ENERGY satisfies the highest qualitative expectations in relation to European and international rules. Insulation is by way of foam of polyurethane (PU) of high-density and elevated thickness to reduce heat loss to a minimum.

Steel tank, glass-lined using the flowcoating method (850 °C).

Flange for boiler inspection Ø 134 mm.

Anti-corrosion anode of magnesium.

Copper sheathed heating element on flange.

Thermostat with external regulation and capillary safety feature.

External boiler shell in sheet metal painted with epoxide powders.

Insulation in foam polyurethane (PU) of elevated thickness without CFCs and HCFCs.

Indicator light.

Dome for protection of electric parts IPX5 complete with cable and "Schuco" plug.

Storage water temperature indicator.

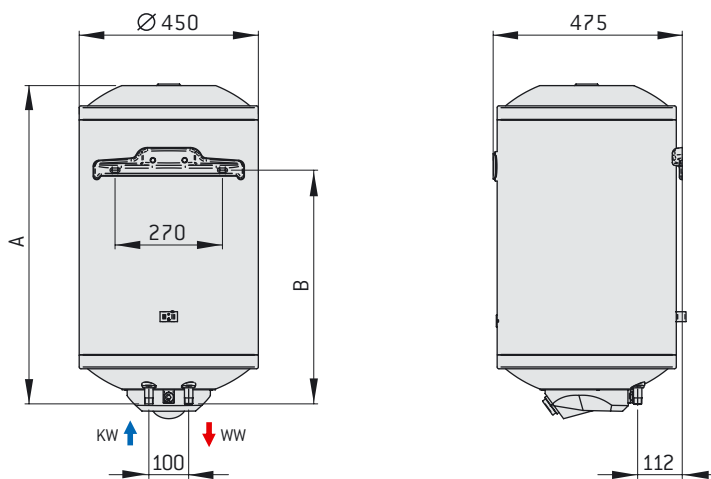
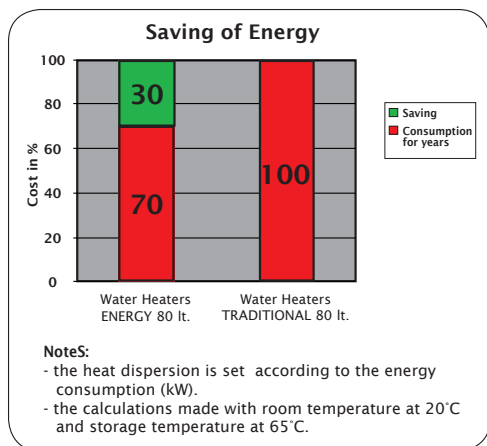

	Capacity	Power	Voltage	Heating time $\Delta t=50^\circ\text{C}$	Insul. thickness	Heat loss 65°C	Max operating temp.	Max operating press.	Net weight	Hydraulic connections	A	B
	l	KW	V~	min	mm	kWh/24h	°C	Mpa	kg	KW-WW	mm	mm
EGY 40	40	1,2	230	122	$\geq 25$	0,78	75	0,8	18,5	R ½	513	292
EGY 50	50	1,2	230	153	$\geq 25$	0,87	75	0,8	21,0	R ½	596	375
EGY 80	80	1,2	230	245	$\geq 25$	1,13	75	0,8	27,0	R ½	799	587
EGY 100	100	1,2	230	306	$\geq 25$	1,30	75	0,8	33,0	R ½	1013	801



# GV

## ELECTRIC WATER HEATERS LT 120 150 200



### High capacity and performance



The new LIKE line of electric water heater of high capacity is designed and produced according to the most up-to-date European standards of efficiency, insulation and design.

#### LT 120

Steel tank, glass-lined using the flowcoating method (850 °C) to ensure maximum purity of the water contained and the durability of the appliance.

Insulation in foam polyurethane.

Safety valve.

Electric unit of 1200W with adjustable internal thermostat (1200W Horizontal model).

#### LT 150-200

Steel tank, glass-lined using the flowcoating method (850 °C) protected against corrosion by anode of magnesium, easy to inspect and replace from outside.

Insulation in foam of polyurethane (containing no CFCs) of considerable thickness.

Electric unit of 1200W with adjustable internal thermostat.

The horizontal models, in addition to being flanged, are equipped with disassembled brackets which may be installed by a right or left heating element connection.

**Optional: converter single/three-phases electric kit, accessories on page 17**

MODEL 120

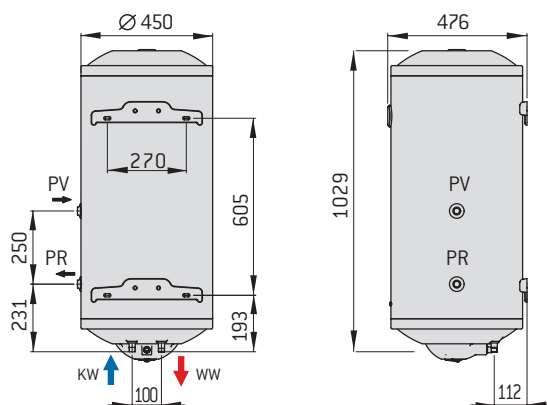

MODEL 150/200

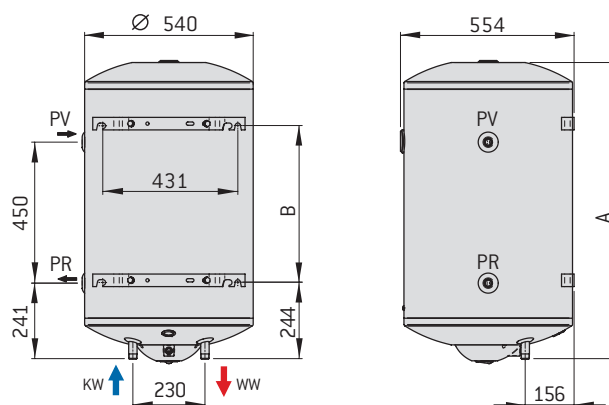

	Capacity	Power	Voltage	Heating time $\Delta t=50^{\circ}\text{C}$	Max operating temperature	Max operating press.	Net weight	Surface area of coil exchanger	Hydraulic connections	Coil connections	A	B
	l	kw	V~	min	$^{\circ}\text{C}$	Mpa	kg	$\text{m}^2$	KW-WW	PV-PR	mm	mm
GV 120	120	1,5	230	295	75	0,8	29	-	R 1/2"	-	-	-
GV 150	150	2,0	230	280	75	0,8	42	-	R 3/4"	-	945	500
GV 200	200	2,0	230	368	75	0,8	51,5	-	R 3/4"	-	1205	800
GV/T 120	120	1,5	230	295	75	0,8	37,0	0,6	R 1/2"	Rp 1/2"	-	-
GV/T 150	150	2,0	230	280	75	0,8	56,5	0,9	R 3/4"	Rp 1/2"	945	500
GV/T 200	200	2,0	230	368	75	0,8	66,0	0,9	R 3/4"	Rp 1/2"	1205	800

LIKE ELECTRIC WATER HEATERS / For Domestic Use



# GO

## ELECTRIC WATER HEATERS LT 120 150 200

LIKE ELECTRIC WATER HEATERS / For Domestic Use

### High capacity and performance



The new LIKE line of electric storage water heaters of high capacity is designed and produced according to the most up-to-date European standards of efficiency, insulation and design.

#### LT 120

Steel tank, glass-lined using the flowcoating method (850 °C) to ensure maximum purity of the water contained and the durability of the appliance.

Insulation in foam polyurethane.

Safety valve.

Electric unit of 1200W with adjustable internal thermostat (1200W Horizontal model).

#### LT 150-200

Steel tank, glass-lined using the flowcoating method (850 °C) protected against corrosion by anode of magnesium, easy to inspect and replace from outside.

Insulation in foam of polyurethane (containing no CFCs) of considerable thickness.

Electric unit of 1200W with adjustable internal thermostat.

The horizontal models, in addition to being flanged, are equipped with disassembled brackets which may be installed by a right or left heating element connection.

**Optional: converter single/three-phases electric kit, accessories on page 17**

MODEL 120

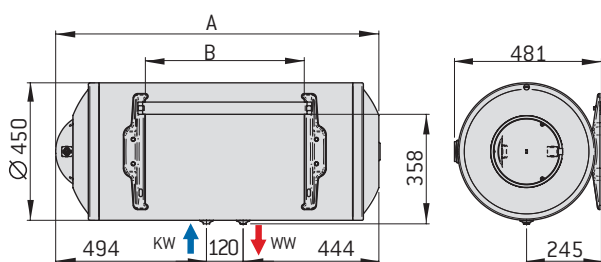

MODEL 150/200

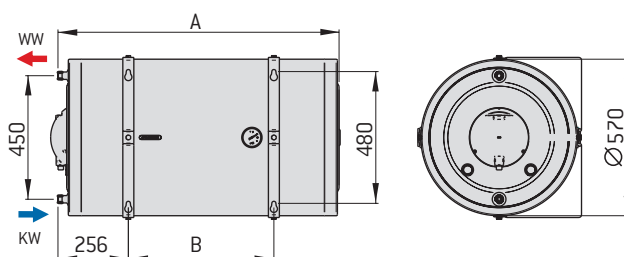

	Capacity	Power	Voltage	Heating time $\Delta t=50^{\circ}\text{C}$	Max operating temperature	Max operating press.	Net weight	Hydraulic connections	A	B
	l	kw	V~	min	$^{\circ}\text{C}$	Mpa	kg	KW-WW	mm	mm
GO 120	120	1,2	230	367	75	0,8	29,0	R 1/2"	1058	520
GO 150	150	2,0	230	280	75	0,8	65,5	R 3/4"	1024	530
GO 200	200	2,0	230	368	75	0,8	71,5	R 3/4"	1294	800





# ELCOX *inox*

ELECTRIC  
WATER HEATERS  
LT 120 160 200  
300 400 500



## Maximum reliability for the professionals of heat



“ELCOX” floor-standing storage electric water heaters are designed to respond to the latest expectations as to durability and perfection.

To this end the “inox” product line has been introduced, representing maximum of quality and durability thanks to the use of special materials such as stainless steel and to sophisticated technological solutions such as “TIG” and “Plasma” welding.

Insulation is by way of foam of polyurethane (PU) of high-density and elevated thickness to reduce heat loss to a minimum. Ideal for community and industrial applications.

Aisi 316L stainless steel boiler welded with “TIG” and “Microplasma” technology.

Frontal inspection hatch Ø 134 mm.

Flange on upper end plate Ø 134 mm complete with counterflange.

Electronic protection device “Correx®” with titanium anode and LED signalling.

Triple heating element in stainless steel incoloy 800.

Thermostat for regulation and capillary safety feature.

Insulation in foam polyurethane (PU) of elevated thickness without CFCs and HCFCs.

Outer cover in coloured plastic material (PVC).

Adjustable feet for floor support.

Storage water temperature indicator.

Accessories on page 17

LIKE ELECTRIC WATER HEATERS / For Collective Use

STAINLESS STEEL HEATING ELEMENT

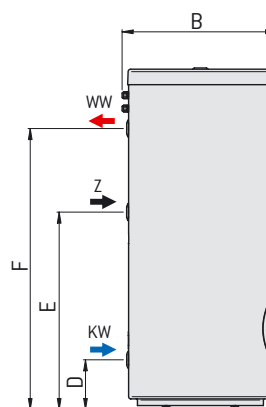
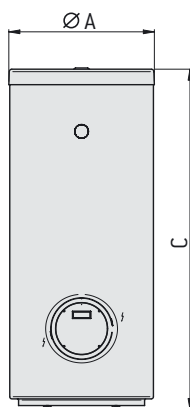
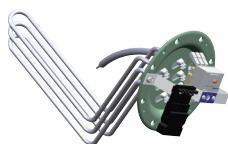

	Capacity	Power	Voltage	Heating time $\Delta t=50^{\circ}\text{C}$	Insul. thickness	Heat loss 65°C	Max operating temp.	Max operating press.	Hydraulic connections	Recirculation	A	B	C	D	E	F
	l	kW	V~	min	mm	kWh/24h	°C	Mpa	KW-WW	Z	mm	mm	mm	mm	mm	mm
ELCOX 120	120	1,5	230	294	≥50	1,50	75	1,0	Rp ¾	Rp ¾	610	654	833	213	443	608
ELCOX 160	160	2,0	230	294	≥50	1,70	75	1,0	Rp ¾	Rp ¾	610	654	1018	213	618	1065
ELCOX 200	200	2,0	230	367	≥50	2,00	75	1,0	Rp ¾	Rp ¾	610	654	1290	213	618	1065
ELCOX 300	300	4,0	400/3	275	≥50	2,40	75	1,0	Rp 1	Rp 1	650	698	1526	228	803	1283
ELCOX 400	400	8,0	400/3	184	≥50	2,80	75	1,0	Rp 1	Rp 1	750	798	1530	263	763	1248
ELCOX 500	500	10,0	400/3	184	≥50	3,30	75	1,0	Rp 1	Rp 1	750	798	1796	263	913	1513



# MEGA ELCOX *inox*

STORAGE TYPE  
LT 800-1000

## Maximum reliability for professionals in the heat

LIKE ELECTRIC WATER HEATERS / For Collective Use



“MEGA ELCOX” floor-standing electric storage water heaters are designed to meet the new expectations of the market as to durability and great storage. To this end, this product line was introduced, providing maximum quality and durability owing to the use of special materials and sophisticated technological solutions, such as TIG and plasma welding.

The guarantee of durability in time is further extended by means of a modern chemical passivation and pickling treatment of the whole tank. The insulation layer is manufactured by means of a new system that combines the technology of the injected polyurethane (PU) with the flexibility of NEOPOR (EPS). This solution allows the installer to have a “plug and play” product and, in case of need, it is an easy solution for making the product pass through openings whose width equals 800 mm. This system allows a trouble-free disassembly and reassembly of the insulation layer for an easier installation in boiler rooms. The two big front hatchways characterise the line of these products and make them flexible and suitable for several combinations of electrical powers up to maximum 20 KW. The electrical components are supplied apart in handy single- and three-phase KITS with Incoloy 800 stainless steel heating elements with powers up to 10 kW. They are recommended for collective use.

AISI 316L stainless steel boiler, welded with “TIG” and “Plasma” technology.

Double Ø134 mm front hatchway for electrical Kit assembly and inspection.

Ø134 mm top bottom-flange complete with counter-flange and probe pipe.

Very thick expanded polyurethane (PU) / (EPS) insulation layer. “Easy entry” system.

External coloured plastic coating.

Adjustable feet for floor standing.

Stored water temperature indicator.

Accessories on page 17

STAINLESS STEEL HEATING ELEMEN

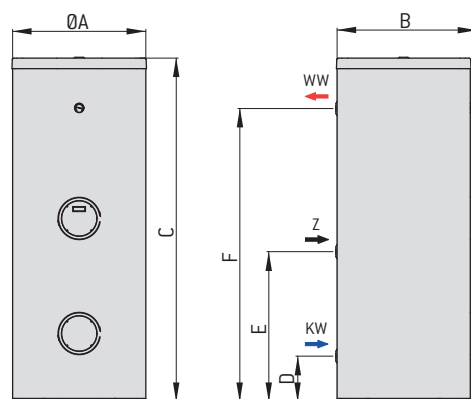
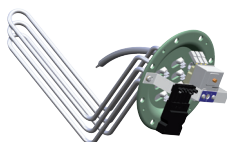

	Capacity	Insul. thickness	Max operating temp.	Max operating press.	Net weight	Hydraulic connections	Recirculation	A	B	C	D	E	F
	l	mm	°C	Mpa	Kg	KW-WW	Z	mm	mm	mm	mm	mm	mm
MEGA ELCOX 800	800	≥110	95	1,0	146	Rp 1 ½	Rp 1 ½	880	925	1865	320	982	1580
MEGA ELCOX 1000	1000	≥110	95	1,0	170	Rp 1 ½	Rp 1 ½	880	925	2245	320	1165	1960



# ELCO

ELECTRIC  
WATER HEATERS  
LT 120 160 200 300  
400 500 600



## Great performance



“ELCO” floor-standing storage electric water heaters are devised to satisfy the highest qualitative expectations as regards compliance with European and international rules.

Insulation is by way of foam of polyurethane (PU) of high-density and elevated thickness to reduce heat loss to a minimum. Ideal for collective and industrial applications.

Steel tank, glass-lined using the flowcoating method (850 °C).

Frontal inspection hatch Ø 134 mm.

Anti-corrosion anode of magnesium.

Copper heating element shielded on hatch.

Thermostat for regulation and safety.

Outer cover in coloured plastic material (PVC).

Insulation in foam polyurethane (PU) of elevated thickness without CFCs and HCFCs.

Dome for protection of electric parts IPX5.

Storage water temperature indicator.

Accessories on page 17

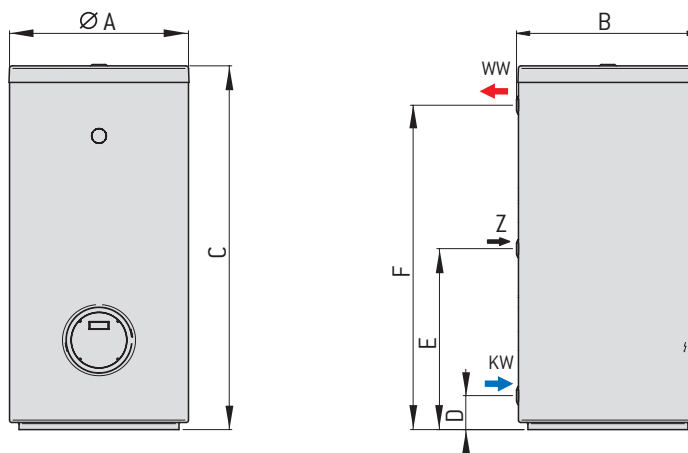

	Capacity	Power	Voltage	Heating time $\Delta t=50^{\circ}\text{C}$	Insul. thickness	Heat loss 65°C	Max operating temp.	Max operating press.	Net weight	Hydraulic connections	Recirculation	A	B	C	D	E	F
	l	kW	V~	min	mm	kWh/24h	°C	Mpa	Kg	KW-WW	Z	mm	mm	mm	mm	mm	mm
ELCO 120	120	1,5	230	294	≥50	1,50	75	1,0	38	Rp ¾	Rp ¾	610	620	854	150	486	720
ELCO 160	160	2,0	230	294	≥50	1,70	75	1,0	46	Rp ¾	Rp ¾	610	620	1056	150	551	922
ELCO 200	200	2,0	230	367	≥50	2,00	75	1,0	53	Rp ¾	Rp ¾	610	620	1329	150	651	1195
ELCO 300	300	3,0	230	367	≥50	2,40	75	1,0	77	Rp 1	Rp 1	650	675	1560	148	828	1408
ELCO 300	300	3,0	400/3	367	≥50	2,40	75	1,0	77	Rp 1	Rp 1	650	675	1560	148	828	1408
ELCO 400	400	4,0	400/3	367	≥50	2,80	75	1,0	99	Rp 1	Rp 1	750	775	1553	162	782	1387
ELCO 500	500	5,0	400/3	367	≥50	3,30	75	1,0	115	Rp 1	Rp 1	750	775	1818	162	932	1652
ELCO 600	600	5,0	400/3	440	≥50	3,60	75	1,0	176	Rp 1	Rp 1	810	832	1819	124	871	1659

LIKE ELECTRIC WATER HEATERS / For Collective Use





# ACCESSORIES & KIT FOR ELECTRIC WATER HEATERS



## GV 150/200

**SINGLE, THREE-PHASE TRANSFORMATION ELECTRICAL KIT**  
formed by: 2" heating element - 3.0 kw - 400/3 V~ installed on the flange, flange gasket, three-phase thermostat and closing cover

## ELCO

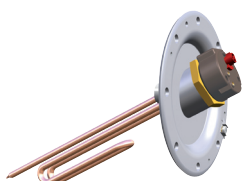

**SINGLE-PHASE ELECTRICAL KIT 1"1/4' - 2,0 KW - 230 V~**  
(heating element + thermostat + counter-flange c/sleeve and gasket)

**SINGLE-PHASE ELECTRICAL KIT 1"1/4' - 3,0 KW - 230 V~**  
(heating element + thermostat + counter-flange c/sleeve and gasket)

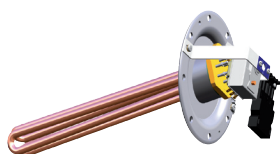

**THREE-PHASE ELECTRICAL KIT 2" 3,0 KW 400/3 V~**  
formed by: counter-flange with 2" sleeve, gasket, copper armoured heating element, thermostat equipped with brackets and connectors

**THREE-PHASE ELECTRICAL KIT 2" 4,0 KW 400/3 V~**  
formed by: counter-flange with 2" sleeve, gasket, copper armoured heating element, thermostat equipped with brackets and connectors

**THREE-PHASE ELECTRICAL KIT 2" 5,0 KW 400/3 V~**  
formed by: counter-flange with 2" sleeve, gasket, copper armoured heating element, thermostat equipped with brackets and connectors

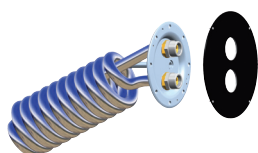

**SPIROID EXCHANGER KIT MQ 1.00**  
FOR ALL SERIES

**SPIROID EXCHANGER KIT MQ 1.80**  
Only for series Lt. 400-500-600-800-1000

## ELCO/ELCOX, MEGA ELCO, MEGA ELCOX

### Inox accessories

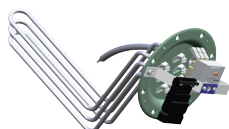

**THREE-PHASE INOX ELECTRICAL KIT 3,0÷6,0 KW - 400 V~**  
(recommended models up to 300 lt.)

**THREE-PHASE INOX ELECTRICAL KIT 4,0÷8,0 KW - 400 V~**  
(recommended models from 400 liters up)

**THREE-PHASE INOX ELECTRICAL KIT 5,0÷10,0 KW - 400 V~**  
(recommended models from 400 liters up)

*Each group consists of:*  
heating element + thermostat + brackets + gasket.



# WOOD-FIRED WATER HEATERS



## THE RANGE

A product which has made the story of LIKE so distinguished, and which LIKE has from the beginning developed from the viewpoint of technological evolution.

The LIKE wood-fire water heater is the eco-friendly solution for antonomasia; on its own or in combination with an electric heating element it represents a low-cost solution to the challenge of protecting the environment.

The decision to develop a single line indicates a clear will to introduce a product that is state-of-the-art for eco-friendly heating for domestic use.

The technologies applied are those of LIKE!

Glass-lined tank and anode of magnesium, with the possibility of electric integration.



# WOOD-FIRED

WOOD-FIRED  
WATER HEATERS  
LT 80



## The wood-fired water heater par excellence



“Wood” water storage heaters make it possible to generate hot water in conditions where traditional energy sources are not available or to utilize forms of renewable energy are environmentally friendly. They are available in electric or thermo-electric models.

Steel tank, glass-lined using the flowcoating method (850 °C).

Anti-corrosion anode of magnesium.

Combustion chamber of heat-resistant material with removable device to collect ash.

Outer cover for combustion chamber in glazed sheet metal.

Insulation in mineral wool to reduce heat loss.

Copper shielded heating element, stem thermostat for regulation and safety (wood-electric model only).

External boiler shell in sheet metal painted with epoxide powders.

Storage water temperature indicator.

Available in the following models: wood, wood-electric and wood thermo-electric.

LIKE WOOD-FIRED

WOOD-FIRED / WOOD-ELECTRIC MODEL

WOOD-FIRED / WOOD-THERMOELECTRIC MODEL

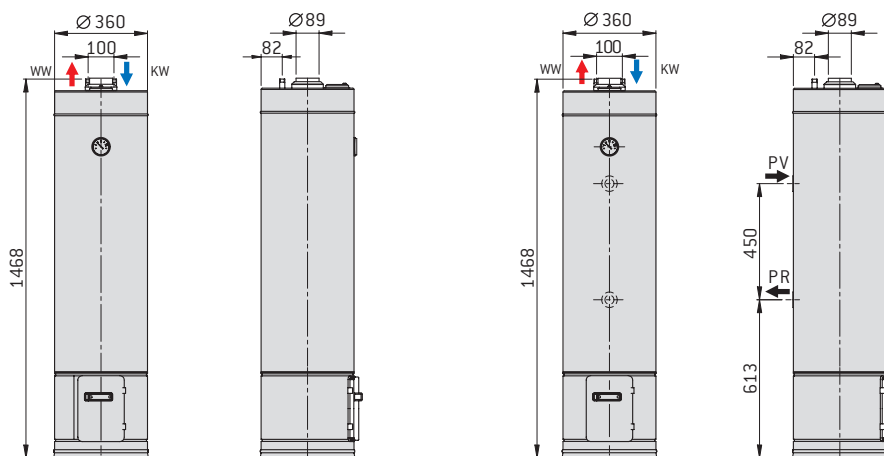

	Capacity	Power	Voltage	Heating time $\Delta t=50^{\circ}\text{C}$	Max operating temperature	Max operating press.	Net weight	Hydraulic connections	Coil connections
	l	kW	V~	min	$^{\circ}\text{C}$	Mpa	Kg	kW-WW	PV-PR
LA/1	80	-	-	-	90	0,8	46	R ½	-
LA/3	80	1,2	230	245	90	0,8	46	R ½	-
LA/4	80	1,2	230	245	90	0,8	49	R ½	Rp ¾



# GAS WATER HEATERS

## THE RANGE

The Like range of gas water heaters is the result of detailed research and in-depth experiments related to the efficiency, safety, aesthetic appearance and energy savings in strict compliance with the applicable norms in force.

The range of capacities covered by this product line is from 50 to 2000 litres with power ratings of between 4 kW and over 34 kW of heat output. The range meets both the domestic requirements of a typical home as well as those of industrial and collective settings.

The product lines include “natural draught” appliances, which are ideal for the rapid and cheap production both small and large quantities of water, as well as the sophisticated “fan flue” appliances which also solve installation difficulties when traditional systems cannot be fitted.

**DOMESTIC USE**  
NATURAL DRAUGHT  
FORCED DRAUGHT

**COLLECTIVE USE**  
NATURAL DRAUGHT  
FORCED DRAUGHT

### THERMAL INSULATION

LIKE has selected only high-density Polyurethane (PU) offered in three configurations of insulation:

Standard / Medium / Hi-Grade.

PU guarantees exceptional thermal insulation, reduced power consumption and optimal performance.

### TANK PROTECTION AGAINST WEAR

Thanks to the “flow-coating” enamelling process at 850°C for guaranteed quality internal protection or via classic hot galvanising process (for series 600-2000 only).

### LIKE DOUBLE GAS

All LIKE gas-fired water heating models are equipped with Double technology, multi-gas burners for methane or LPG, freedom of use and flexibility.

### MAGNESIUM ANODE

LIKE mounts in its water heaters only Magnesium Anodes which effectively combat the natural process of corrosion.

### MAXIMUM SAFETY

Triple-security gas valve with operating thermostat, thermocouple flame sensor (ionized for electronic models), thermostat for over-temperature and device for control of exhaust gases (for natural draught models) to avert possible malfunctioning.

### LIKE EASY CHECK

External regulation allows easy and fast modulation of the water temperature. LIKE has developed broad diameter flanges to allow easy inspection, cleaning and maintenance of internal components.

### ENVIRONMENTALLY FRIENDLY

Like strives to optimise its industrial activity while respecting the environment. To minimise the environmental impact of its products, it has abolished the use of chlorofluorocarbons (CFC-HCFC) in the insulation layer and makes continuous efforts to use recyclable components.



# SGAN

GAS WATER HEATER  
WALL MOUNTED STORAGE  
OPEN CHAMBER  
NATURAL DRAUGHT  
LT 50 80 100 120



## Safety and practicality for all domestic environments



Wall-mounted storage gas water heaters with atmospheric and natural draught represent the simplest and most economic solution for fast generation of hot water for domestic use.

Steel tank, glass-lined using the flowcoating method (850 °C).

Anti-corrosion anode of magnesium.

Insulation in foam polyurethane (PU) free from CFCs and HCFCs.

External boiler shell of sheet metal painted with epoxide powders.

Piezoelectric ignition.

3 ramp burner.

Gas valve with 3 safety features: operating thermostat, thermocouple flame sensor and control of overtemperature.

Gas control sensor (DCF).

Water storage temperature indicator.

Preset for methane gas transformable into LPG (nozzles included).

Functioning in absence of electric wiring.

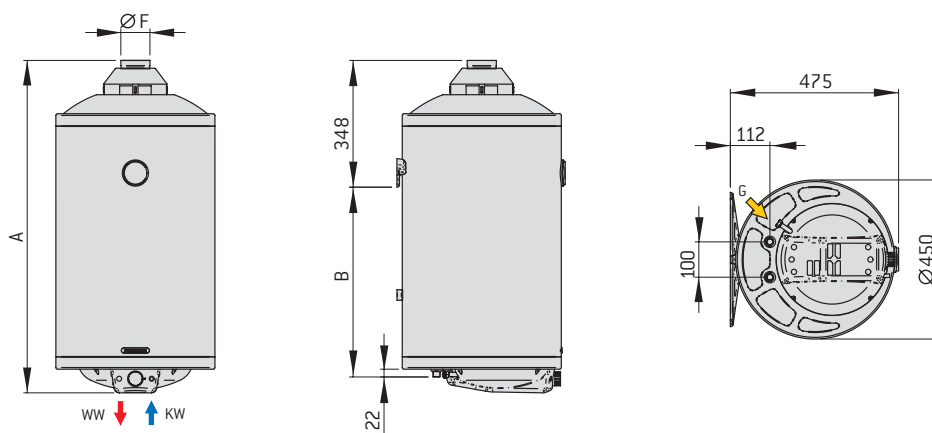

	Capacity	Heat input	Effective output	Heating time $\Delta t=50^{\circ}\text{C}$	Continuous flow rate $\Delta t=30^{\circ}\text{C}$	Max. quant. of exhaust gases	Temp. of exhaust gases	Methane consumption	LPG consumption	Max. operating temp.	Max. operating press.	Net weight	Hydraulic connections	Gas connection	Gas discharge $\varnothing$	C	D
	l	kW	kW	min	l/min	g/s	$^{\circ}\text{C}$	$\text{m}^3/\text{h}$	g/h	$^{\circ}\text{C}$	Mpa	Kg	kW-WW	G	F (mm)	mm	mm
SGAN 50	50	4,5	3,8	43	1,8	1,96	308	0,50	300	75	0,8	20	Rp 1/2	G 3/8	81	654	261
SGAN 80	80	6,2	5,3	55	2,5	2,75	292	0,65	395	75	0,8	28	Rp 1/2	G 3/8	81	939	546
SGAN 100	100	6,2	5,3	65	2,5	3,22	284	0,65	395	75	0,8	32	Rp 1/2	G 3/8	81	1024	631
SGAN 120	120	6,5	5,6	77	2,7	3,31	275	0,70	425	75	0,8	36	Rp 1/2	G 3/8	81	1174	781

Note: open Chamber, natural Draught B<sub>1185</sub>; Category II 2H3+

LIKE GAS-FIRED / For Domestic Use



# SGA CSE

GAS WATER HEATER  
WALL MOUNTED STORAGE  
OPEN CHAMBER  
FORCED DRAUGHT  
LT 80 120

## Ideal for special applications

Wall-mounted storage gas water heaters with sealed chamber and "forced draught" represent a sophisticated but brilliant way of dealing with the most difficult conditions of engineering installation, where the use of an alternative to traditional appliances for fast generation of hot water for domestic use is not permitted.

Steel tank, glass-lined using the flowcoating method (850 °C).

Anti-corrosion anode of magnesium;

Insulation in foam polyurethane (PU) free of CFCs and HCFCs.

External boiler shell of sheet metal painted with epoxide powders.

Electronic ignition with ionized flame sensing and control.

Fan for extraction of exhaust gases with safety pressure gauge.

Gas valve with 3 safety features: operating thermostat, ionized flame sensing and control of overtemperature.

Storage water temperature indicator.

Preset for methane gas transformable into LPG (nozzles included).

Possibility for coaxial or split smoke discharge.

Accessories on page 27



LIKE GAS-FIRED / For Domestic Use

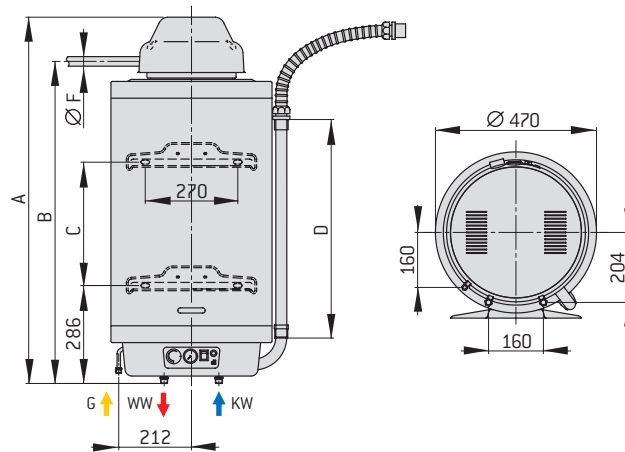

	Capacity	Heat input	Effective output	Heating time $\Delta t=50^{\circ}\text{C}$	Continuous flow rate $\Delta t=30^{\circ}\text{C}$	Max. quant. of exhaust gases	Temp. of exhaust gases	Methane consumption	LPG consumption	Max. operating temp.	Max. operating press.	Net weight	Hydraulic connections	Gas connection	Gas discharge $\varnothing$	A	B	C	D
	l	kW	kW	min	l/min	g/s	$^{\circ}\text{C}$	$\text{m}^3/\text{h}$	g/h	$^{\circ}\text{C}$	Mpa	Kg	kW-WW	G	F (mm)	mm	mm	mm	mm
SGA/80CSE	80	4,0	3,4	84	1,6	2,20	91	0,42	246	75	0,8	40	R ½	Rp ¾	28	1069	940	360	632
SGA/120CSE	120	4,0	3,4	127	1,6	2,20	91	0,42	246	75	0,8	48	R ½	Rp ¾	28	1300	1171	591	867

Note: Sealed chamber, Forced draught  $\text{C}_{12}$   $\text{C}_{32}$   $\text{C}_{42}$   $\text{C}_{82}$ ; Category II 2H3+; power consumption: 44W -230V~



# BAG

GAS WATER HEATER  
WALL MOUNTED STORAGE  
OPEN CHAMBER  
NATURAL DRAUGHT  
LT 120 150 200



## The best solution for large quantities of hot water



Floor-standing storage gas water heaters with atmospheric and natural draught represent the best way of generating high qualities of sanitary hot water.

Also ideal for community applications (camping grounds, sporting and hotel complexes) and industrial applications.

Steel boiler enamel glazed with flow coating method (850°C).

Anti-corrosion anode of magnesium;

Insulation in foam polyurethane (PU) free of CFCs and HCFCs.

External boiler shell of sheet metal painted with epoxide powders.

Piezoelectric ignition.

Storage water temperature indicator.

Gas valve with 3 safety features: operating thermostat, thermocouple flame sensor and control of overtemperature.

Gas control sensor (DCF).

Preset for methane gas transformable into LPG (nozzles included).

Functioning without electrical connections.

BAG 120-150

BAG 200

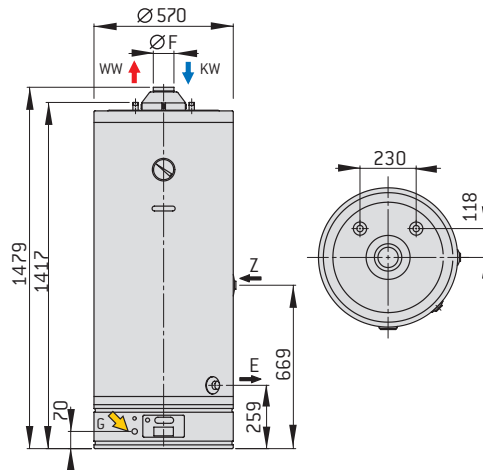
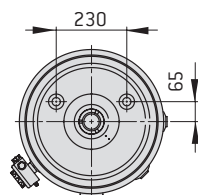
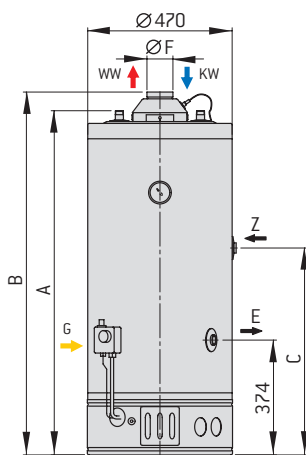

	Capacity	Heat input	Effective output	Heating time $\Delta t=50^\circ\text{C}$	Continuous flow rate $\Delta t=30^\circ\text{C}$	Max. quant. of exhaust gases	Temp. of exhaust gases	Methane consumption	LPG consumption	Max. operating temp.	Max. operating press.	Net weight	Hydraulic connections	Recirculation and discharge	Gas connection	Gas discharge $\varnothing$	A	B	C
	l	kW	kW	min	l/min	g/s	$^\circ\text{C}$	$\text{m}^3/\text{h}$	g/h	$^\circ\text{C}$	Mpa	Kg	kW-WW	Z-E	G	F (mm)	mm	mm	mm
BAG 120	120	6,9	5,7	72	2,7	3,36	284	0,75	445	75	0,8	41	R $\frac{3}{4}$	Rp $\frac{3}{4}$	R $\frac{1}{2}$	81	1212	1274	674
BAG 150	150	7,2	6,0	92	2,8	3,80	242	0,76	445	75	0,8	50	R $\frac{3}{4}$	Rp $\frac{3}{4}$	R $\frac{1}{2}$	81	1511	1573	824
BAG 200	200	8,0	6,6	111	3,2	3,76	234	0,84	495	75	0,8	71	R $\frac{3}{4}$	Rp $\frac{3}{4}$	R $\frac{1}{2}$	81	vedi schema		

Note: Open chamber, Natural draught B<sub>1185</sub>, Category II 2H3+

LIKE GAS-FIRED / For Collective Use



# BAG

GAS WATER HEATER  
FLOOR-STANDING STORAGE  
OPEN CHAMBER  
NATURAL DRAUGHT  
LT 300 500

LIKE GAS-FIRED / For Collective Use



## High quantity of water and better quality/price ratio

Floor-standing storage gas water heaters with open chamber and “natural draught” were designed for accumulation of high quantities of hot water while having regard to the best ratio between quality and price. The model with electronic ignition allows one to combine inexpensive running costs with maximum precision of flame control. Ideal for community applications (camping grounds, sporting and hotel complexes) and industrial applications.

Steel tank, glass-lined using the flowcoating method (850 °C).

Frontal inspection hatch Ø 134 mm.

Anti-corrosion anode of magnesium.

Insulation in foam polyurethane (PU) free from CFCs and HCFCs.

External boiler shell of sheet metal painted with epoxide powders.

Gas control sensor (DCF).

Piezoelectric ignition; (electronic for model BAG/AE).

Gas valve with 3 safety features: operating thermostat, thermocouple flame sensor (ionized for BAG/AE models) and control of overtemperature.

Storage water temperature indicator.

Preset for methane gas transformable into LPG (nozzles included).

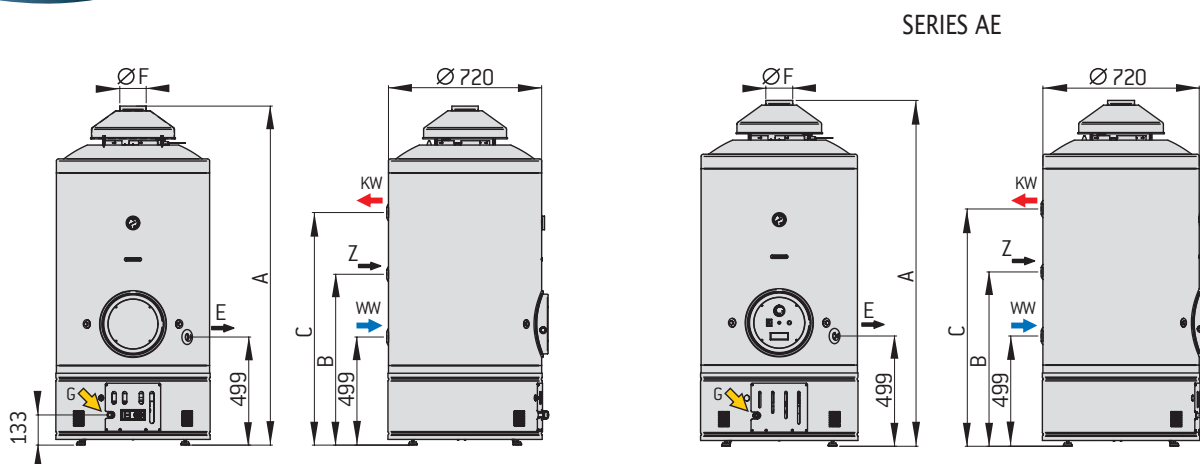

	Capacity	Heat input	Effective output	Heating time $\Delta t=50^{\circ}\text{C}$	Continuous flow rate $\Delta t=30^{\circ}\text{C}$	Max. quant. of exhaust gases	Temp. of exhaust gases	Methane consumption	LPG consumption	Max. operating temp.	Max. operating press.	Net weight	Hydraulic connections	Recirculation and discharge	Gas connection	Gas discharge $\varnothing$	A	B	C
	l	kw	kw	min	l/min	g/s	$^{\circ}\text{C}$	$\text{m}^3/\text{h}$	g/h	$^{\circ}\text{C}$	Mpa	Kg	kw-WW	Z-E	G	F (mm)	mm	mm	mm
BAG/300	300	19,5	17,2	62	8,2	9,59	230	2,10	1250	75	0,8	133	Rp 1	Rp $\frac{3}{4}$	R $\frac{3}{4}$	122	1611	821	1084
BAG/500	500	24,0	21,0	82	10,0	11,58	214	2,52	1500	75	0,8	178	Rp 1	Rp $\frac{3}{4}$	R $\frac{3}{4}$	122	2144	1285	1643
BAG/300 AE	300	19,5	17,2	62	8,2	9,59	230	2,10	1250	75	0,8	133	Rp 1	Rp $\frac{3}{4}$	R $\frac{3}{4}$	122	1611	821	1084
BAG/500 AE	500	24,0	21,0	82	10,0	11,58	214	2,52	1500	75	0,8	178	Rp 1	Rp $\frac{3}{4}$	R $\frac{3}{4}$	122	2144	1285	1643

Note: For electronic model BAG/AE connection to the electric network is indicated - 230 V~; Open chamber, Natural draught B<sub>11BS</sub>; Category II 2H3+



# MEGA BAG

GAS WATER HEATER  
FLOOR-STANDING STORAGE  
OPEN CHAMBER  
NATURAL DRAUGHT  
LT 600 800 1000 1500 2000



## Extensive availability of hot water, modularity



Floor-standing storage open-vented and “natural draught” high capacity gas water heaters provide large quantities of hot water and can be installed in series/parallel where large consumption levels are required.

The version featuring electronic ignition combines economic use with maximum flame control precision. These water heaters are ideal for collective use (on campsites, in sports facilities and hotels, for example) and in industrial settings.

Hot galvanised steel tank.

Corrosion-proof magnesium anode.

Very thick mineral wool insulation layer for reduced heat loss.

Stored water temperature indicator.

External casing made of pre-painted sheet metal.

Piezoelectric ignition.

Triple safety gas valve: operating thermostat, flame detection thermocouple and maximum temperature control.

Flue gas sensor (DCF).

Designed to operate on methane gas or LPG (nozzles included).

Operation without electrical connections.

Electronic version (EG/PE) available upon request.

LIKE GAS-FIRED / For Collective Use

	Capacity	Heat Output	Useful Power	Heat. time $\Delta t=50^{\circ}\text{C}$	Cont. flow rate $\Delta t=30^{\circ}\text{C}$	Max. qty. of flue gases	Flue gas temp.	Methane consumption	LPG consumption
	l	kW	kW	min	l/min	g/s	$^{\circ}\text{C}$	$\text{m}^3/\text{h}$	g/h
BAG 600	600	26,7	22,9	92	10,9	23,2	136	2,70	1988
BAG 800	800	34,8	29,9	98	14,3	31,1	135	3,60	2581
BAG 1000	1000	34,8	30,2	115	14,3	31,1	135	3,60	2581
BAG 1500	1500	34,8	29,6	180	14,1	31,1	135	3,60	2581
BAG 2000	2000	34,8	30,2	225	14,3	31,1	135	3,60	2581

Note: open-vented, natural draught B<sub>1185</sub> / category II 2H3+

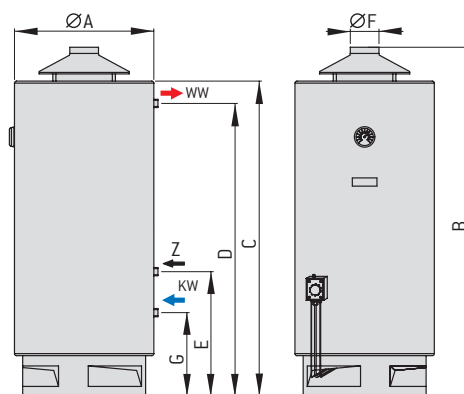

	Max. operating temp.	Max. operating press.	Net Weight	Hydraulic fittings	Recirculation and discharge	Gas fitting	Ø Flue gas discharge	A	B	C	A	B	C
	$^{\circ}\text{C}$	Mpa	Kg	kW-WW	Z-E	G	F (mm)	mm	mm	mm	mm	mm	mm
BAG 600	75	0,6	194	Rp 1	Rp 1	R ½	140	780	2165	2000	1730	1010	310
BAG 800	75	0,6	241	Rp 1¼	Rp 1¼	R ½	160	980	1975	1810	1470	900	340
BAG 1000	75	0,6	276	Rp 1¼	Rp 1¼	R ½	160	1080	2025	1860	1470	900	340
BAG 1500	75	0,6	377	Rp ½	Rp 1¼	R ½	160	1180	2255	2090	2000	960	340
BAG 2000	75	0,6	452	Rp 1¼	Rp 1¼	R ½	160	1280	2475	2310	2150	960	340



# SGA CSE

GAS WATER HEATER  
FLOOR-STANDING STORAGE  
SEALED CHAMBER  
FORCED DRAUGHT  
LT 220 300 400

LIKE GAS-FIRED / For Collective Use



## Advanced technology for large loads and demanding situations

Floor-standing storage gas water heaters with sealed chamber and "forced draught" give an advanced technical solution to the trickiest installation problems.

Electronic management makes them ideal for community applications (camping grounds, sporting and hotel complexes) and industrial applications.

Steel tank, glass-lined using the flowcoating method (850 °C).

Anti-corrosion anode of magnesium with anode control device.

Insulation in mineral wool of elevated thickness.

External boiler shell in pre-painted sheet metal.

Electronic ignition with ionized flame observation and control.

Fan for extraction of gases with safety pressure gauge.

Gas valve with 3 safety features: operating thermostat, ionized flame sensing and control of overtemperature.

Time programmer.

Storage water temperature indicator.

Preset for methane gas transformable into LPG (nozzles included).

Possibility for coaxial or split smoke discharge.

Accessories on page 27

	Capacity	Heat input	Effective output	Heating time $\Delta t=50^{\circ}\text{C}$	Continuous flow rate $\Delta t=30^{\circ}\text{C}$	Max. quant. of exhaust gases	Temp. of exhaust gases	Methane consumption	LPG consumption
	l	kW	kW	min	l/min	g/s	$^{\circ}\text{C}$	$\text{m}^3/\text{h}$	g/h
SGA/200 CSE	220	26,7	24,1	33	11,5	16,8	172	2,82	2100
SGA/300 CSE	300	30,6	27,1	29	14,6	16,7	162	3,25	2400
SGA/400 CSE	400	30,6	27,1	29	14,6	17,3	157	3,25	2400

Note: Room-sealed, Fan flue C<sub>12</sub> C<sub>32</sub> C<sub>42</sub> C<sub>82</sub> / Category II 2H3+ / Absorbed power: 62W - 230V~

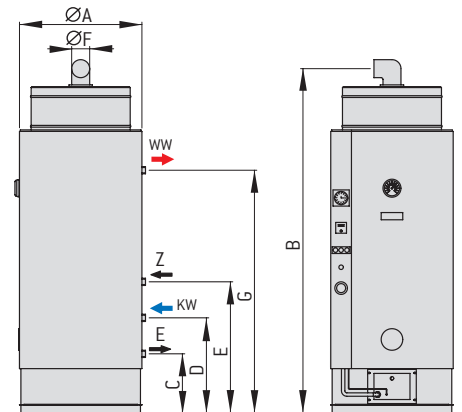

	Max. operating temp.	Max. operating press.	Net weight	Hydraulic connections	Recirculation and discharge	Gas connection	Gas discharge $\varnothing$	A	B	C	A	B	C
	$^{\circ}\text{C}$	Mpa	Kg	kW-WW	Z-E	G	F (mm)	mm	mm	mm	mm	mm	mm
SGA/220 CSE	75	0,6	141	Rp 1	Rp 1	R ½	100	640	1750	390	590	790	1150
SGA/300 CSE	75	0,6	170	Rp 1	Rp 1	R ½	100	640	1975	390	590	790	1375
SGA/400 CSE	75	0,6	210	Rp 1	Rp 1	R ½	100	690	2150	390	590	790	1540

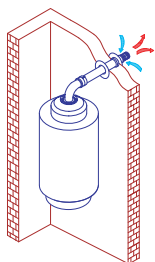

## BSC, BSS, BSD, MEGA BSS, MEGA BSD

### COAXIAL OUTLET KIT Ø 60/28 MM - 1 METRE

coaxial mouth - 1m Ø60/28 mm coaxial pipe  
discharge/suction end - wall cover roses

Ø 60/28 MM COAXIAL EXTENSION CORD - 0.5 METRES

Ø 60/28 MM COAXIAL EXTENSION CORD - 1.0 METRE

90° Ø 60/28 MM COAXIAL ELBOW

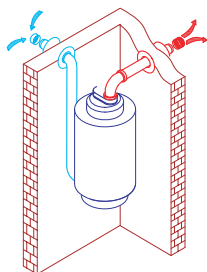

## BSC, BSS, BSD, MEGA BSS, MEGA BSD

### Ø 32/28 MM SPLIT OUTLET KIT - 1 METRE

n. 1 1 metre Ø 28 mm outlet extension cord  
n. 1 1metre Ø 32 mm outlet extension cord  
discharge/suction end - wall cover roses

Ø 28 MM OUTLET EXTENSION CORD - 0.5 METRES

Ø 28 MM OUTLET EXTENSION CORD - 1.0 METRE

Ø 32 MM SUCTION EXTENSION CORD - 0.5 METRES

Ø 32 MM SUCTION EXTENSION CORD - 1.0 METRE

90° Ø 28 MM OUTLET ELBOW

45° Ø 28 MM OUTLET ELBOW

90° Ø 32 MM SUCTION ELBOW

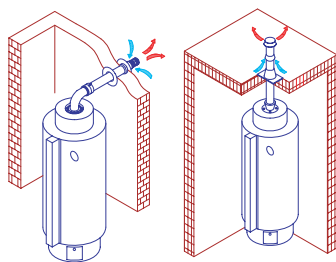

Scarico coassiale

Scarico a tetto

## BSC, BSS, BSD, MEGA BSS, MEGA BSD

### COAXIAL OUTLET KIT Ø 60/100 MM - 1 METRE

multi-directional 90° coaxial elbow with inspections, coaxial pipe  
and discharge/suction end

VERTICAL Ø 60/100 MM FLANGED COAXIAL STUB PIPE

Ø 60/100 MM COAXIAL EXTENSION CORD - 1.0 METRE

90° Ø 60/100MM COAXIAL ELBOW

### COAXIAL OUTLET KIT ON ROOF Ø 80/110 MM - 1 METRE

coaxial pipe, flanged concentric 118-100 reduction, gasket, 80-60 reduction;  
device for roof outlet equipped with sleeve and fastening screws

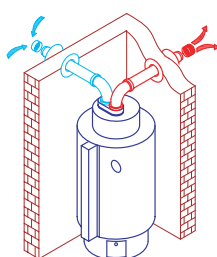

## BSC, BSS, BSD, MEGA BSS, MEGA BSD

### Ø 80/-80MM SPLIT OUTLET KIT - 1 METRE

formed by: splitter with condensation outlet and inspections,  
n.2 90° elbows, n.2 extension cords, suction/discharge ends

Ø 80 MM EXTENSION CORD - 1 METRE

90° Ø 80 MM ELBOW



# INDIRECT CYLINDERS

## THE RANGE

**SINGLE COIL**  
UNDERMOUNT  
FREE STANDING  
FREE STANDING INOX

**DOUBLE COIL**  
FREE STANDING  
FREE STANDING INOX

**INTERCAVITY**  
MULTIPOSITION

LIKE indirect heating indirect cylinders are designed to give fast and abundant supply of hot water for all types of use.

They are devised to be suited for all kinds of integration with autonomous, centralized or municipal heating systems or to be used in forced circulation solar heating plants.

Very high efficiency

Like indirect cylinders are high performance products studied to guarantee maximum efficiency with minimum energy consumption.

Double or single coil, like indirect cylinders with one or two coils hold a range of litre capacities from 115 to 600 litre with working capacity between 20 kw to over 100 kw of power. The possibility of combining models permits the construction of systems which satisfy any litre capacity exigency.

The tilt of the lower coils ensures uniform heating even in “problematic” zones where bacteria formation is more likely.

Under-boiler indirect cylinders: compatible with any wall-mounted boiler.

Free Standing: flexibility and freedom of installation with adjustable feet for a stable and levelled support.

Multipositional: free vertical, horizontal and floor-standing.



THE TECHNOLOGY WHICH  
MAKES THE DIFFERENCE

## LIKE INOX

The latest INOX line embraces the philosophy of total quality and of advanced construction technology. The result is a line of products without compromise, designed to last and to offer the maximum, just as on the first day of installation.

AISI 316L STAINLESS STEEL  
Stainless Steel of superior quality.

SPECIAL TIG AND PLASMA  
WELDING

Guarantees the same resistance also in junction points.

## THERMAL INSULATION

LIKE has selected only high-density Polyurethane (PU) offered in three insulation configurations.

## TANK PROTECTION AGAINST WEAR

Thanks to the “flow-coating” enamelling process at 850°C for guaranteed quality internal protection.

## ENVIRONMENTALLY FRIENDLY

Like strives to optimise its industrial activity while respecting the environment. To minimise the environmental impact of its products, it has abolished the use of chlorofluorocarbons (CFC-HCFC) in the insulation layer and makes continuous efforts to use recyclable components.

## MAGNESIUM ANODE

It is to be found in all products within the range and makes the boiler’s electrochemical protection constantly effective.

## ACTIVE ANTI-CORROSION PROTECTION CORREX® (OPTIONAL)

The Correx® system is the latest technology in terms of active tank protection, and is fitted with a PCB, a control LED and a transmitted current titanium anode. This system solves all your anode-replacement and limescale removal problems.



# BMI

INDIRECT CYLINDER  
MULTIPOSITIONAL  
INDIRECT HEATING  
LT 80 100 115 150 200 300

## The multipositional practical and economical



“Multipositional” intercavity storage indirect cylinders are a practical and economic solution for production of sanitary hot water.

Their particular quality lies in the complete range from 80 to 300 litres and their versatility of installation and additionally, due to reduced pressure loss, they are ideal in natural circulation systems. Suitable for domestic and collective use.

Steel tank, glass-lined using the flowcoating method (850 °C).

Inspection flange Ø 88 mm complete with counterflange with sensor sheath.

Anti-corrosion magnesium anode.

Intercavity exchanger optimized for natural circulation installations thanks to reduced pressure losses.

Foam polyurethane (PU) insulation no CFCs and HCFCs.

Recirculation connection.

External boiler shell in sheet metal painted with epoxide powders.

Primary circuit connections on two sides for maximum installation flexibility.

Possibility of multipositional installation: vertical or horizontal on wall or on floor (model 300 may be installed on floor only).

Electric Integration kits available (not for model 300 l).

Foot extension kit for floor-standing series installation on the 300lt. (Optional for other models).

Accessories on page 48

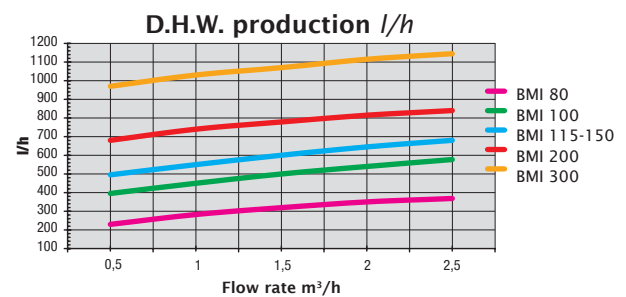
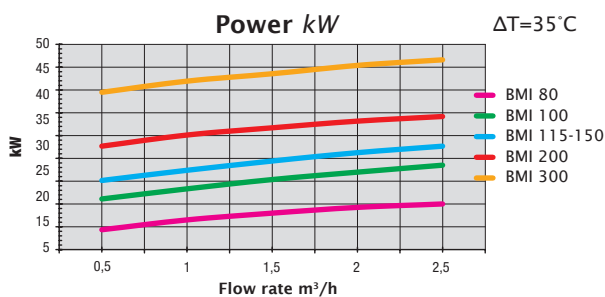
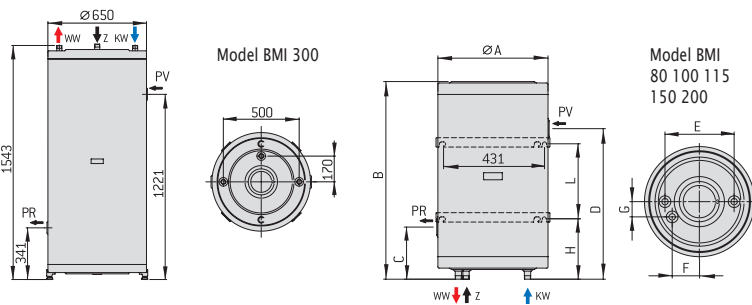

	Capacity	Exchange surface	Power (Δt 35k)*	D.H.W. production (Δt 35k)*	Heating time (Δt 35k)*	Primary flow rate	Max operating temp	Max operating press.						
	l	m²	kW	l/h	min	m³/h	°C	Mpa						
BMI 80	80	0,65	14	350	15	2,0	95	0,8						
BMI 100	100	0,90	22	540	12	2,0	95	0,8						
BMI 115	115	1,10	26	645	11	2,0	95	0,8						
BMI 150	150	1,10	26	645	15	2,0	95	0,8						
BMI 200	200	1,50	33	815	16	2,0	95	0,8						
BMI 300	300	2,00	45	1115	17	2,0	95	0,8						
	Max. operating pressure of air asing	Net weight	Hydraulic connections	Heat exchanger connections	Recirculation connections	A	B	C	D	E	F	G	H	L
	Mpa	Kg	KW-WW	PV-PR	Z	mm	mm	mm	mm	mm	mm	mm	mm	mm
BMI 80	0,4	42	R ¾	Rp 1¼	R ¾	470	844	223	463	295	65	65	257	320
BMI 100	0,4	51	R ¾	Rp 1¼	R ¾	470	1057	223	856	295	65	65	257	500
BMI 115	0,4	59,5	R ¾	Rp 1¼	R ¾	470	1228	223	1027	295	65	65	257	670
BMI 150	0,4	67	R ¾	Rp 1¼	R ¾	570	1025	214	819	450	115	115	262	500
BMI 200	0,4	83,5	R ¾	Rp 1¼	R ¾	570	1295	214	1086	450	115	115	262	800
BMI 300	0,4	130	R 1	Rp 1¼	R 1	see diagram								

Note: \*Primary temperature 80°C / Secondary 10 /45°C / Primary flow rate indicated in the table -D.H.W. = domestic hot water.

LIKE INDIRECT CYLINDERS / Double wall



# BSC

INDIRECT CYLINDER  
UNDER-BOILER  
INDIRECT HEATING  
LT 115 150

## Universal wellness

Single coil vertical storage “under-boiler” indirect cylinders are devised for combination with any type of wall-mounted boiler to generate high quantities of hot water despite the moderate dimensions. Suitable for domestic use.

Steel tank, glass-lined using the flowcoating method (850 °C).

Upper inspection flange Ø 134 mm complete with counterflange with sensor sheath (Tr).

Anti-corrosion anode of magnesium.

Coil with depressed loop optimized for maximum heat exchange and reduced limescale formation.

Recirculation and discharge connections.

External boiler shell of sheet metal painted with epoxide powders.

Hydraulic connections installed in the upper section/part for easy coupling with a wall-mounted boiler.

Insulation in foam polyurethane (PU) of elevated thickness without CFCs and HCFCs.

Feet for floor support.

Storage water temperature indicator.

Accessories on page 48

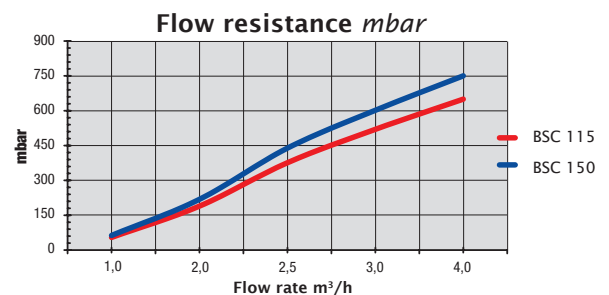
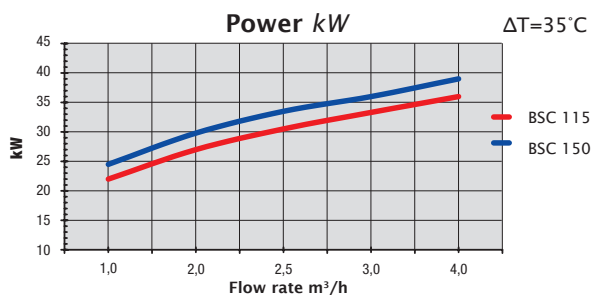
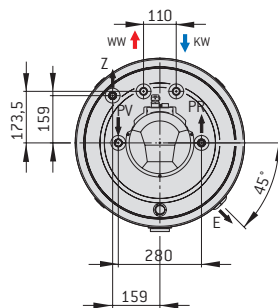
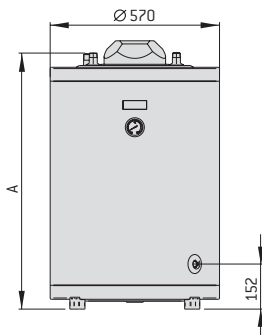

	Capacity	Exchange surface	Power (Δt 35k)*	D.H.W. production (Δt 35k)*	Heating time (Δt 35k)*	Pressure loss	Primary flow rate	Insulation thickness	Heat loss 65°C
	l	m²	kW	l/h	min	mbar	m³/h	mm	kWh / 24 h
BSC 115	115	0,90	27	663	11	189	2,0	≥ 35	1,30
BSC 150	150	1,00	30	732	13	219	2,0	≥ 35	1,90
	Max. operating temp.	Max. operating press.	Net weight	Hydraulic connections	Heat exchanger connections	Recirculation connections	Discharge connection	A	
	°C	Mpa	Kg	KW-WW	PV-PR	Z	E	mm	
BSC 115	95	1,0	53	R ¾	R ¾	R ¾	Rp ½	862	
BSC 150	95	1,0	61	R ¾	R ¾	R ¾	Rp ½	1064	

Note: \*Primary temperature 80°C / Secondary 10 / 45°C / Primary flow rate indicated in the table - D.H.W. = Domestic hot water.



# BSQ

INDIRECT CYLINDER  
UNDER-BOILER  
INDIRECT HEATING  
LT 120 160

## Universal wellness



“Undermount Indirect cylinders SWT” vertical single coil storage indirect cylinders are designed to be combined with any wall-hung boiler for the production of large quantities of hot water despite space restrictions.

The rectangular shape can be suitably fitted as an undermount indirect cylinder. The coloured PVC coating enhances its lines and protects it against possible collisions during assembly operations and normal use. In addition, the product has been designed so that it can be complete-

ly disassembled at the end of its life cycle, in a way to allow its correct recycling and/or the disposal of its components. It is recommended for domestic use.

Steel tank, glass-lined using the flowcoating method (850 °C).

Ø 134 mm top inspection flange complete with counter-flange and probe sheath (Tr).

Corrosion-proof magnesium anode.

Streamlined coil for the maximum heat exchange process and to reduce the formation of limescale.

Outlet and recirculation fittings.

Hydraulic fittings installed in the upper part to facilitate the connection with a wall-hung boiler.

Self-extinguishing and very thick high-density (EPS) polystyrene-shell insulation layer.

Anti-collision external coloured PVC coating.

Adjustable feet for floor standing.

Stored water temperature indicator.

Drain cock.

Accessories on page 48

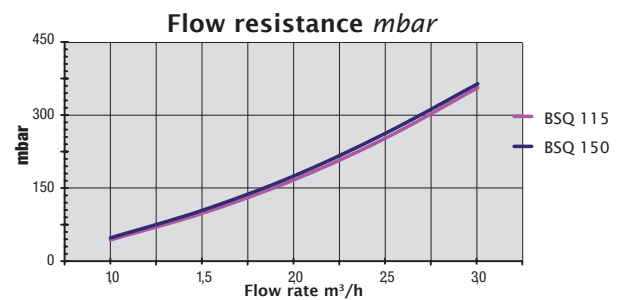
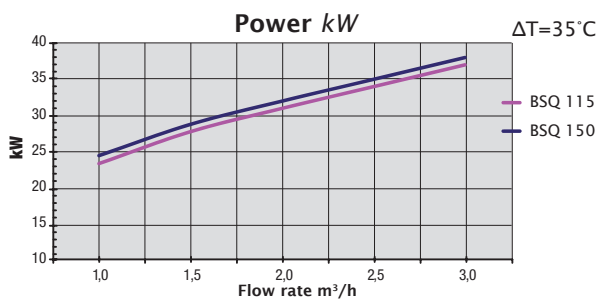
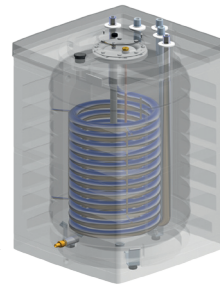
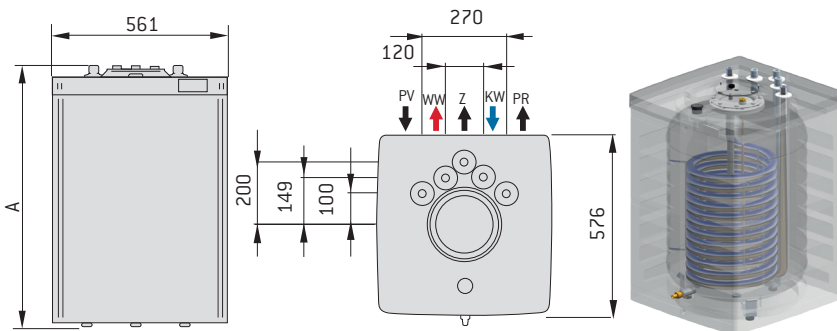

	Capacity	Exchange surface	Power (Δt 35k)*	D.H.W. production (Δt 35k)*	Heating time (Δt 35k)*	Pressure loss	Primary flow rate	Insulation thickness	Heat loss 65°C
	l	m²	kW	l/h	min	mbar	m³/h	mm	kWh / 24 h
BSQ 115	115	1,15	32	780	10	170	2,0	≥ 30	2,30
BSQ 150	150	1,20	32	780	13	172	2,0	≥ 30	2,70
	Max. operating temp.	Max. operating press.	Net weight	Hydraulic connections	Heat exchanger connections	Recirculation connections	Discharge connection	A	
	°C	Mpa	Kg	KW-WW	PV-PR	Z	E	mm	
BSQ 115	95	1,0	54	R ¾	G ¾	R ¾	Rp ½	845	
BSQ 150	95	1,0	64	R ¾	G ¾	R ¾	Rp ½	1045	

Note: \*Primary temperature 80°C / Secondary 10 / 45°C / Primary flow rate indicated in the table - D.H.W. = Domestic hot water.

LIKE INDIRECT CYLINDERS / Single Coil





**BSSX** *inox*

INDIRECT CYLINDER  
FREE STANDING  
INDIRECT HEATING  
LT 120 160 200 300 400 500

LIKE INDIRECT CYLINDERS / Single Coil



***Ideal construction quality for collective and industrial applications***

Single coil “BSSX stainless steel” storage indirect cylinders are produced through technology that guarantees maximum quality and durability, thanks to the use of special materials and sophisticated technological solutions such as “TIG” and “Plasma” welding. Suitable for industrial and collective applications.

Aisi 316L stainless steel boiler welded with “TIG” and “Microplasma” technology.

Front inspection hatch Ø 134 mm.

Flange at upper end Ø 134 mm complete with counterflange with sensor sheath (Tr).

Coil with depressed loops optimized for maximum heat exchange and reduced limescale formation.

Hydraulic connections installed in the rear section.

Outer cover in coloured plastic material (PVC).

Recirculation connection.

Storage water temperature indicator.

Insulation in foam polyurethane (PU) of elevated thickness without CFCs and HCFCs.

Adjustable feet for floor support.

Integration kits available for use of heating elements in stainless steel incoloy 800 up to 10 kW with mono and three-phase connections.

Available on request, model with electronic protection device “Correx®” with titanium anode and LED signalling.

**Accessories on page 48**

	Capacity	Exchange surface	Power (Δt 35k)*	D.H.W. production (Δt 35k)*	Heating time (Δt 35k)*	Pressure loss	Primary flow rate	Insulation thickness	Heat loss 65°C	Max operating temp.
	l	m <sup>2</sup>	kW	l/h	min	mbar	m <sup>3</sup> /h	mm	kWh / 24 h	°C
BSSX 120	120	0,60	27,0	663	11	115	2,0	≥ 50	1,50	95
BSSX 160	160	0,80	36,5	896	11	117	2,0	≥ 50	1,70	95
BSSX 200	200	1,00	40,5	995	13	178	2,0	≥ 50	2,00	95
BSSX 300	300	1,40	59,0	1460	13	140	3,0	≥ 50	2,40	95
BSSX 400	400	2,00	81,0	1989	13	183	3,0	≥ 50	2,80	95
BSSX 500	500	2,40	91,0	2229	14	235	3,0	≥ 50	3,30	95

Note: \*Primary temperature 80°C / Secondary 10 / 45°C / Primary flow rate indicated in the table - D.H.W. = domestic hot water.



Power kW

$\Delta T=35^{\circ}\text{C}$

Flow resistance mbar

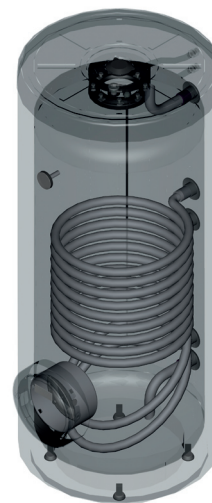
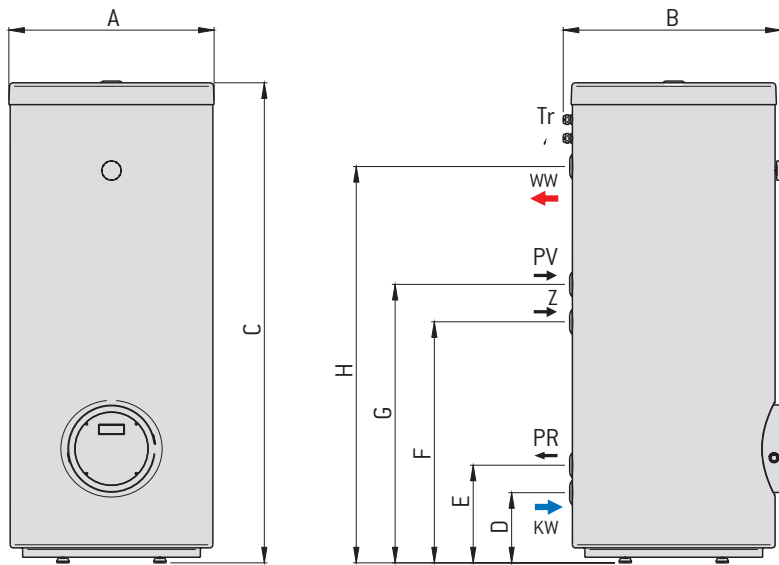
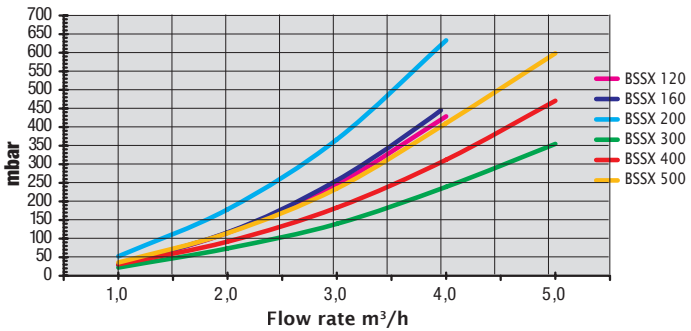
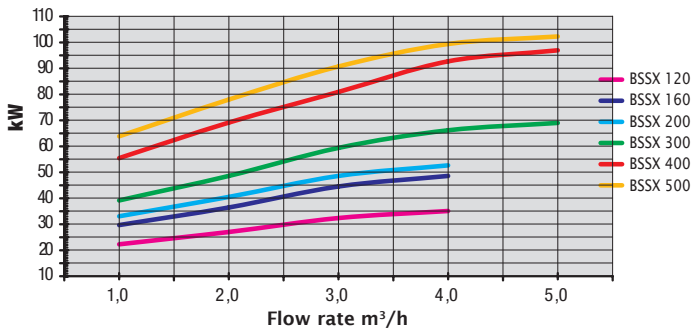

3D radiography

	Max operating press.	Net weight	Hydraulic connections	Heat exchanger connections	Recirculation connections	A	B	C	D	E	F	G	H
	Mpa	Kg	KW-WW	PV-PR	Z	mm	mm	mm	mm	mm	mm	mm	mm
BSSX 120	1,0	38	Rp ¾	Rp ¾	Rp ¾	610	654	833	213	323	443	533	608
BSSX 160	1,0	43	Rp ¾	Rp ¾	Rp ¾	610	654	1018	213	323	518	683	793
BSSX 200	1,0	51	Rp ¾	Rp ¾	Rp ¾	610	654	1290	213	323	618	783	1065
BSSX 300	1,0	87	Rp 1	Rp 1	Rp 1	650	698	1526	228	338	803	918	1283
BSSX 400	1,0	93	Rp 1	Rp 1	Rp 1	750	798	1530	263	373	763	1063	1248
BSSX 500	1,0	110	Rp 1	Rp 1	Rp 1	750	798	1796	263	373	913	1153	1513



# MEGA BSSX *inox*

INDIRECT CYLINDER  
FREE STANDING  
INDIRECT HEATING  
LT 800 1000

## *Ideal construction quality for collective and industrial applications*

“Interline high storage inox” floor-standing electric storage water heaters are designed to meet the new expectations of the market as to durability and great storage. To this end, this product line was introduced, providing maximum quality and durability owing to the use of special materials and sophisticated technological solutions, such as TIG and plasma welding.

The guarantee of durability in time is further extended by means of a modern chemical passivation and pickling treatment of the whole tank. The insulation layer is manufactured by means of a new system that combines the technology of the injected polyurethane (PU) with the flexibility of NEOPOR (EPS). This solution allows the installer to have a “plug and play” product and, in case of need, it is an easy solution for making the product pass through openings whose width equals 800 mm. This system allows a trouble-free disassembly and reassembly of the insulation layer for an easier installation in boiler rooms. The two big front hatchways characterise the line of these products and make them flexible and suitable for several combinations of electrical powers up to maximum 20 kW. The electrical components are supplied apart in handy single- and three-phase KITS with Incoloy 800 stainless steel heating elements with powers up to 10 kW. They are recommended for collective use.

AISI 316L stainless steel boiler, welded with “TIG” and “Plasma” technology.

Double Ø134 mm front hatchway for electrical Kit assembly and inspection.

Ø134 mm top bottom-flange complete with counter-flange and probe pipe.

Very thick expanded polyurethane (PU) / (EPS) insulation layer. “Easy entry” system.

External coloured plastic coating.

Adjustable feet for floor standing.

Stored water temperature indicator.

**Accessories on page 48**



LIKE INDIRECT CYLINDERS / Single Coil

	Capacity	Insul. thickness	Exchange surface	Power (Δt 35k)*	D.H.W. production (Δt 35k)*	Heating time (Δt 35k)*	Primary flow rate	Max operating temp.
	l	mm	m <sup>2</sup>	kW	l/h	min	m <sup>3</sup> /h	°C
MEGA BSSX 800	800	≥ 100	3,05	110	2703	18	3,0	95
MEGA BSSX 1000	1000	≥ 100	3,55	130	3194	19	3,0	95

Note: \*Primary temperature 80°C / Secondary 10 / 45°C / Primary flow rate indicated in the table - D.H.W. = domestic hot water



3D radiography



“Easy entry” system

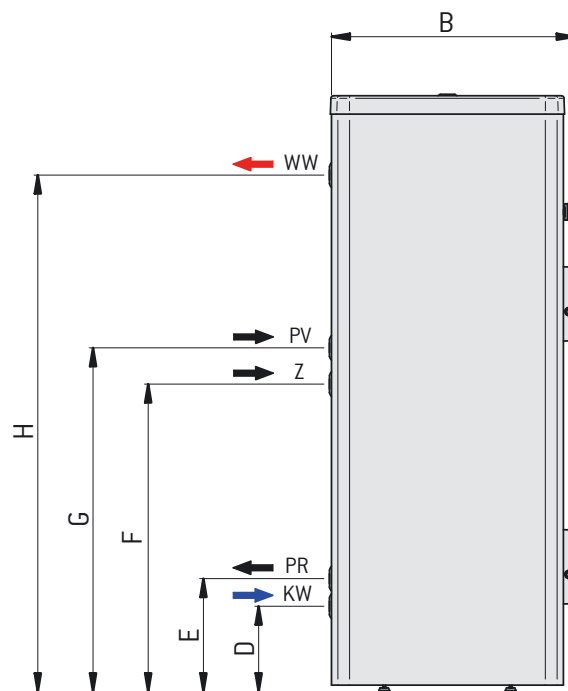
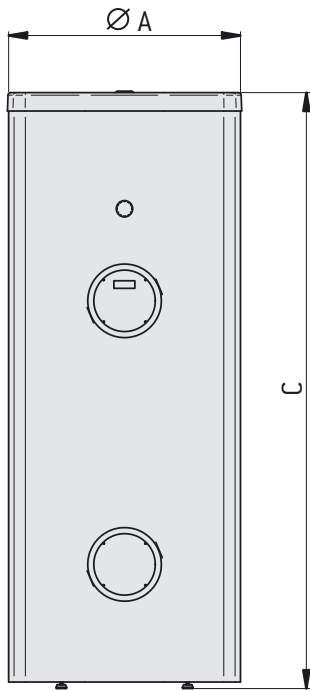
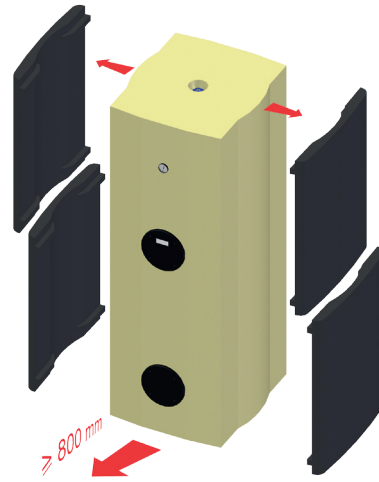

LIKE INDIRECT CYLINDERS

	Max operating press.	Net weight	Hydraulic connections	Heat exchanger connections	Recirculation connections	A	B	C	D	E	F	G	H
	Mpa	Kg	KW-WW	PV-PR	Z	mm	mm	mm	mm	mm	mm	mm	mm
MEGA BSSX 800	1,0	195	Rp 1 ½	Rp 1 ½	Rp 1 ½	880	925	1865	320	425	982	1187	1580
MEGA BSSX 1000	1,0	226	Rp 1 ½	Rp 1 ½	Rp 1 ½	880	925	2245	320	425	1165	1303	1960



# BSS

INDIRECT CYLINDERS  
FREE STANDING  
INDIRECT HEATING  
LT 120 160 200 300 400 500 600

LIKE INDIRECT CYLINDERS / Single Coil



## The Free Standing for large production

Single coil "BSS" storage indirect cylinders are indirect heating boilers. They facilitate easy and abundant generation of hot water for all types of use. They may be connected to centralized systems and equipped with additional integration systems. Ideal for industrial and collective applications.

Steel tank, glass-lined using the flowcoating method (850 °C).

Frontal inspection hatch Ø 134 mm.

Anti-corrosion anode of magnesium.

Coil with depressed loops optimized for maximum heat exchange and reduced limescale formation.

Recirculation connection.

Two sensor sheaths (Tr) installed in the rear section.

Hydraulic connections installed in the rear section.

Outer cover in coloured plastic material (PVC).

Adjustable feet for floor support.

Insulation in foam polyurethane (PU) of elevated thickness without CFCs and HCFCs.

Storage water temperature indicator.

Integration kits available for use of spiroidal exchangers in tinned copper or heating elements in copper up to 5 kW and in stainless steel incoloy 800 up to 10 kW with mono and three-phase connections.

**Accessories on page 48**

	Capacity	Exchange surface	Power (Δt 35k)*	D.H.W. production (Δt 35k)*	Heating time (Δt 35k)*	Pressure loss	Primary flow rate	Insulation thickness	Heat loss 65°C	Max operating temp.
	l	m <sup>2</sup>	kW	l/h	min	mbar	m <sup>3</sup> /h	mm	kWh / 24 h	°C
BSS 120	120	0,60	20	491	15	119	2,0	≥ 50	1,50	95
BSS 160	160	0,85	27	663	15	182	2,0	≥ 50	1,70	95
BSS 200	200	1,00	30	737	17	223	2,0	≥ 50	2,00	95
BSS 300	300	1,40	44	1081	18	138	3,0	≥ 50	2,40	95
BSS 400	400	1,70	55	1351	19	180	3,0	≥ 50	2,80	95
BSS 500	500	2,10	63	1543	20	223	3,0	≥ 50	3,30	95
BSS 600	600	2,90	70	1720	31	75	3,0	≥ 50	3,60	95

Note: \*Primary temperature 80°C / Secondary 10 / 45°C / Primary flow rate indicated in the table - D.H.W. = domestic hot water

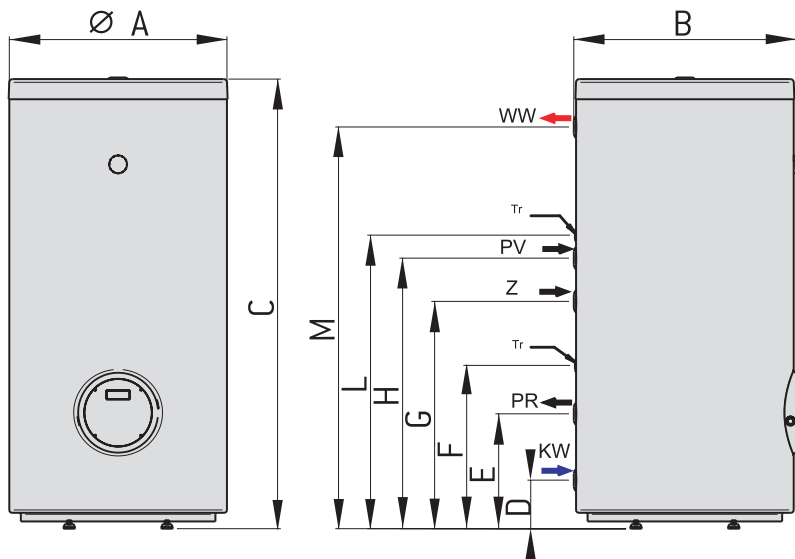
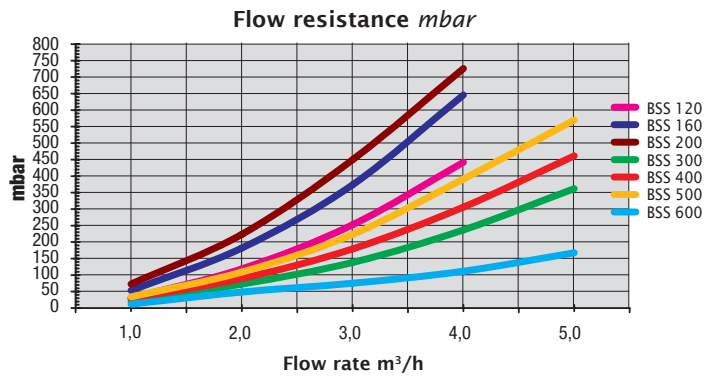
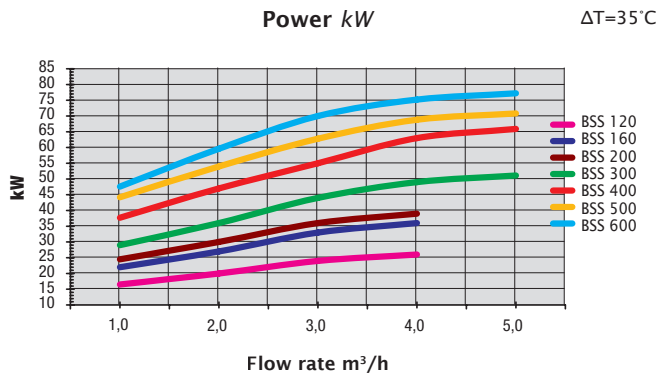

3D radiography

	Max operating press.	Net weight	Hydraulic connections	Heat exchanger connections	Recirculation connections	Number of sensors	A	B	C	D	E	F	G	H	L	M
	Mpa	Kg	KW-WW	PV-PR	Z	Tr	mm	mm	mm	mm	mm	mm	mm	mm	mm	mm
BSS 120	1,0	45	Rp ¾	Rp ¾	Rp ¾	2	610	620	854	150	311	414	486	571	631	720
BSS 160	1,0	57	Rp ¾	Rp ¾	Rp ¾	2	610	620	1056	150	311	416	551	701	781	922
BSS 200	1,0	66	Rp ¾	Rp ¾	Rp ¾	2	610	620	1329	150	311	486	651	801	881	1195
BSS 300	1,0	97	Rp 1	Rp 1	Rp 1	2	650	675	1560	148	338	538	828	978	1058	1408
BSS 400	1,0	123	Rp 1	Rp 1	Rp 1	2	750	775	1553	162	392	560	782	932	1012	1387
BSS 500	1,0	144	Rp 1	Rp 1	Rp 1	2	750	775	1818	162	392	554	932	1082	1162	1652
BSS 600	1,0	220	Rp 1	Rp 1¼	Rp 1	2	810	832	1819	124	331	456	871	1161	1241	1659



# MEGA BSS

INDIRECT CYLINDER  
FREE STANDING  
INDIRECT HEATING  
LT 800 1000

LIKE INDIRECT CYLINDERS / Single Coil



## The Free Standing for big storage

“Free Standing One high storage” single fixed coil floor-standing storage indirect cylinders are designed to meet the new expectations of the market as to durability, exchange power and great storage.

To this end, this new high-capacity product line was introduced, providing maximum quality and durability owing to the use of special materials and sophisticated technological solutions.

The guarantee of durability in time is further extended by means of a modern “glass-lining” treatment over the tank.

The insulation layer is manufactured by means of a new system that combines the technology of the injected polyurethane (PU) with the flexibility of NEOPOR (EPS). This solution allows the installer to have a “plug and play” product and, in case of need, it is an easy solution for making the product pass through openings whose width equals 800 mm.

This system allows a trouble-free disassembly and re-assembly of the insulation layer for an easier installation in boiler rooms.

The two big front hatchways characterise the line of these products and make them flexible and suitable for several combinations of electrical powers up to maximum 20 kW. The electrical components are supplied

apart in handy single and three-phase KITS with Incoloy 800 stainless steel heating elements with powers up to 10 kW or made of copper up to 5 kW. Furthermore, you can equip the tank with spiroid exchangers, if any, which can be installed in the hatchways. They are recommended for collective use.

Steel tank, glass-lined using the flowcoating method (850 °C).

Double Ø 134 mm front hatchway for electrical Kit assembly and inspection.

Ø 134 mm top bottom-flange complete with counter-flange.

Exchanger with lowered coil turns to streamline the heat exchange process and reduce the formation of limescale.

Very thick expanded polyurethane (PU) / (EPS) insulation layer. “Easy entry” system

External coloured plastic coating.

Adjustable feet for floor standing.

Stored water temperature indicator.

They are available in electrical integration kits with the use of Incoloy 800 stainless steel heating elements up to 10 kW with single- and three-phase connections.

**Accessories on page 48**

	Capacity	Insul. thickness	Exchange surface	Power ( $\Delta t$ 35k)*	D.H.W. production ( $\Delta t$ 35k)*	Heating time ( $\Delta t$ 35k)*	Primary flow rate	Max operating temp.
	l	mm	m <sup>2</sup>	kW	l/h	min	m <sup>3</sup> /h	°C
BSS 800	800	≥ 100	3,00	88	2162	24	3,0	95
BSS 1000	1000	≥ 100	3,50	100	2457	26	3,0	95

Nota: \*Temperatura primario 80°C / Secondario 10 /45°C / Portata primario indicata in tabella - A.C.S. = acqua calda sanitaria.



3D radiography

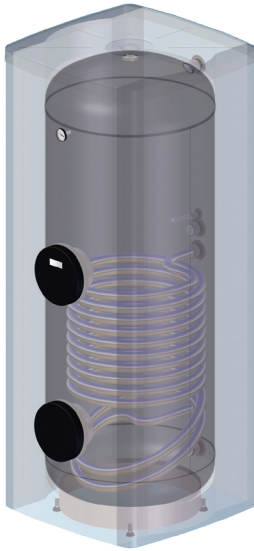

“Easy entry” system

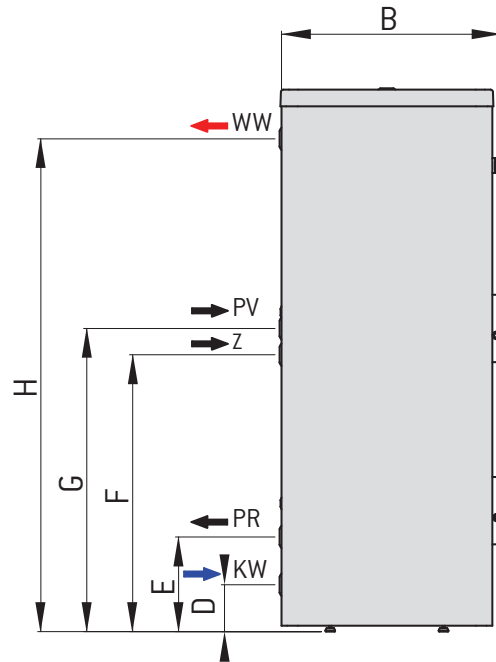
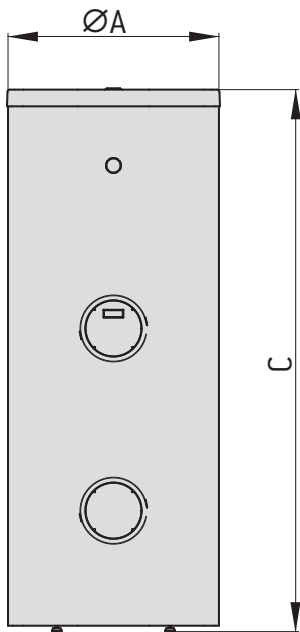
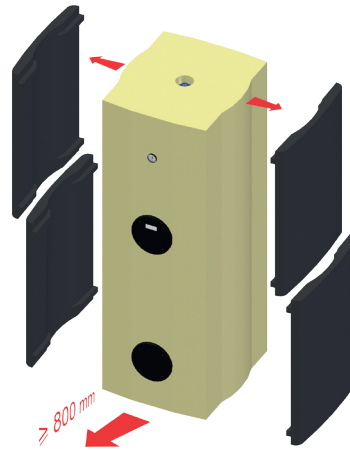

LIKE INDIRECT CYLINDERS

	Max operating press.	Net weight	Hydraulic connections	Heat exchanger connections	Recirculation connections	A	B	C	D	E	F	G	H
	Mpa	Kg	KW-WW	PV-PR	Z	mm	mm	mm	mm	mm	mm	mm	mm
BSS 800	1,0	272	Rp 1 ¼	Rp 1 ¼	Rp 1 ¼	880	925	1865	191	371	1071	971	1676
BSS 1000	1,0	299	Rp 1 ¼	Rp 1 ¼	Rp 1 ¼	880	925	2245	191	371	1231	1121	2056



# BSDX *inox*

INDIRECT CYLINDERS  
FREE STANDING  
INDIRECT HEATING  
LT 300 400 500

LIKE INDIRECT CYLINDERS / Doble Coil



## Quality that repays in time

Double coil "BSDX stainless steel" storage indirect cylinders are produced with technology which guarantees maximum quality and durability through time thanks to the use of special materials and to sophisticated technological solutions such as "TIG" and "Plasma" welding. They may be connected to centralized systems, forced circulation solar heating plants and equipped with additional integration systems. Suitable for industrial and collective use.

Aisi 316L stainless steel boiler welded with "TIG" and "Plasma" technology.

Front inspection hatch Ø 134 mm.

Flange on upper end Ø 134 mm complete with counterflange with sensor sheath (Tr).

Double coil optimized for maximum heat exchange and reduced limescale formation.

Recirculation connection.

Insulation in foam polyurethane (PU) of elevated thickness without CFCs and HCFCs.

Hydraulic connections installed in the rear section.

Outer cover in coloured plastic material (PVC).

Adjustable feet for floor support.

Storage water temperature indicator.

Integration kits available for use of heating elements in stainless steel incoloy 800 up to 10 kW with mono and three-phase connections.

Available on request, model with electronic protection device "Correx®" with titanium anode and LED signalling.

**Accessories on page 48**

	Capacity	Coil position	Exchange surface	Power (Δt 35k)*	D.H.W. production (Δt 35k)*	Heating time (Δt 35k)*	Pressure loss	Primary flow rate	Insulation thickness	Heat loss 65°C	Max operating temp.
	l	top./bot.	m <sup>2</sup>	kW	l/h	min	mbar	m <sup>3</sup> /h	mm	kWh / 24 h	°C
BSDX 300	300	top	0,80	41	1006	19	130	3,0	≥ 50	2,40	95
		bottom	1,30	59	1460	13	140				
BSDX 400	400	top	0,80	41	1006	25	130	3,0	≥ 50	2,80	95
		bottom	1,60	65	1605	16	147				
BSDX 500	500	top	0,80	41	1006	31	130	3,0	≥ 50	3,30	95
		bottom	2,10	81	1989	16	183				

Note: \*Primary temperature 80°C / Secondary 10 / 45°C / Primary flow rate indicated in the table - D.H.W. = domestic hot water. -sup. = upper coil; -inf. = lower coil



Power kW

$\Delta T=35^{\circ}\text{C}$

Flow resistance mbar

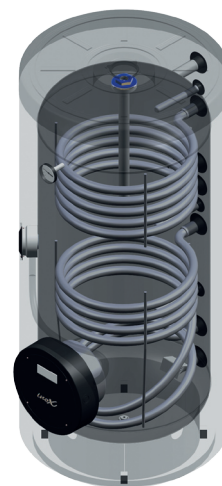
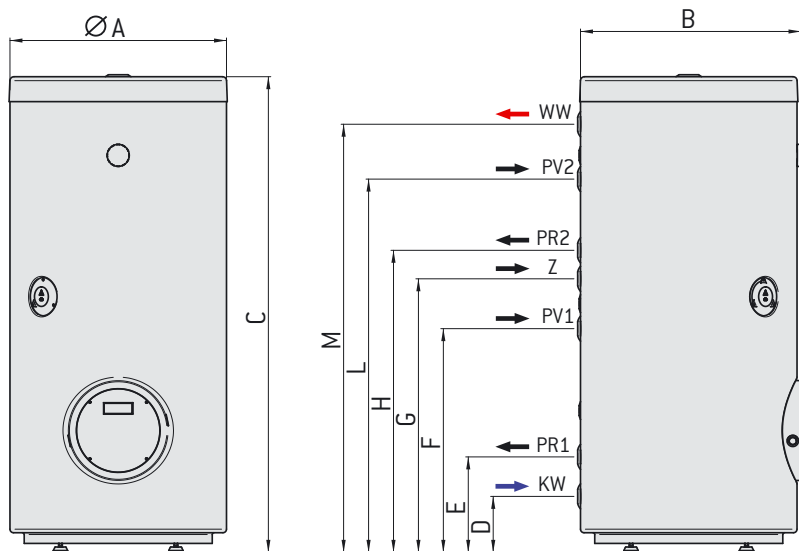
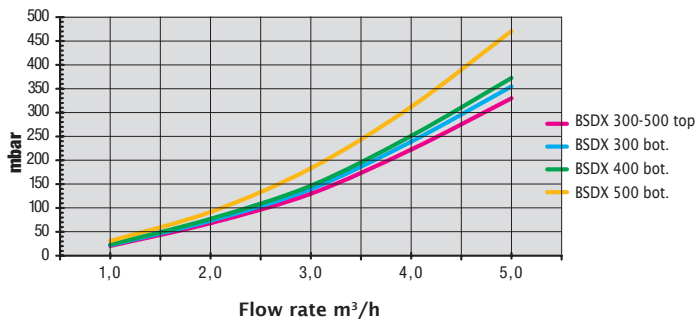
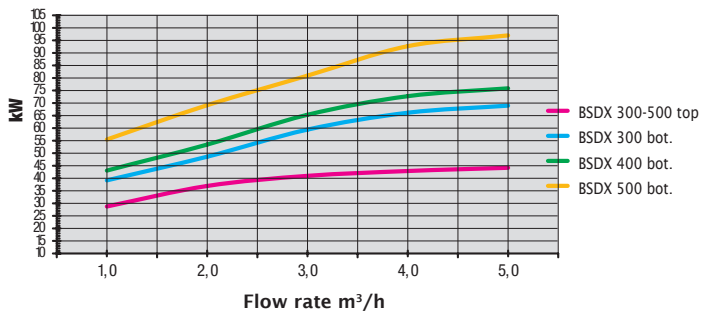

3D radiography

	Max operating press.	Net weight	Hydraulic connections	Heat exchanger connections	Recirculation connections	A	B	C	D	E	F	G	H	L	M
	Mpa	Kg	KW-WW	PV-PR	Z	mm	mm	mm	mm	mm	mm	mm	mm	mm	mm
BSDX 300	1,0	93	Rp 1	Rp 1	Rp 1	650	698	1526	228	320	688	843	969	1191	1283
BSDX 400	1,0	100	Rp 1	Rp 1	Rp 1	750	798	1530	263	355	965	848	971	1156	1248
BSDX 500	1,0	114	Rp 1	Rp 1	Rp 1	750	798	1796	263	355	855	1043	1208	1393	1513



# MEGA BSDX *inox*

INDIRECT CYLINDER  
FREE STANDING  
INDIRECT HEATING  
LT 800 1000

LIKE INDIRECT CYLINDERS / Doble Coil



## The quality for big storage

“Free Standing Two high storage inox” double fixed coil floor-standing storage indirect cylinders are designed to meet the new expectations of the market as to durability, exchange power and great storage. To this end, this product line was introduced, providing great capacities, maximum quality and durability owing to the use of special materials and sophisticated technological solutions, such as TIG and plasma welding.

The guarantee of durability in time is further extended by means of a modern chemical passivation and pickling treatment of the whole tank. The insulation layer is manufactured by means of a new system that combines the technology of the injected polyurethane (PU) with the flexibility of NEOPOR (EPS). This solution allows the installer to have a “plug and play” product and, in case of need, it is an easy solution for making the product pass through openings whose width equals 800 mm. This system allows a trouble-free disassembly and re-assembly of the insulation layer for an easier installation in boiler rooms. The two big front hatchways characterise the line of these products and make them flexible and suitable for several combinations of electrical integrations. They are recommended for collective use.

AISI 316L stainless steel boiler, welded with “TIG” and “Plasma” technology.

Double Ø 134 mm front hatchway for electrical Kit assembly and inspection.

Ø 134 mm top bottom-flange complete with counter-flange and probe pipe.

Exchangers with lowered turns to streamline the heat exchange and reduce the formation of limescale.

Very thick expanded polyurethane (PU) / (EPS) insulation layer. “Easy entry” system.

External coloured plastic coating.

Adjustable feet for floor standing.

Stored water temperature indicator.

They are available in electrical integration kits with the use of Incoloy 800 stainless steel heating elements up to 10 kW with single- and three-phase connections.

Upon demand, the version with “Correx®” electronic protection device, titanium anode and signalling LED is available.

**Accessories on page 48**

	Capacity	Coil position	Exchange surface	Power ( $\Delta t$ 35k)*	D.H.W. production ( $\Delta t$ 35k)*	Heating time ( $\Delta t$ 35k)*	Primary flow rate	Insulation thickness	Max operating temp.
	l	top/bot.	m <sup>2</sup>	kW	l/h	min	m <sup>3</sup> /h	mm	°C
MEGA BSDX 800	800	top	1,30	59	1460	13	3,0	≥ 100	95
		bottom	3,05	110	2703	18			
MEGA BSDX 1000	1000	top	1,30	59	1460	13	3,0	≥ 100	95
		bottom	3,55	130	3194	19			

Note: \*Primary temperature 80°C / Secondary 10 / 45°C / Primary flow rate indicated in the table - D.H.W. = domestic hot water. -sup. = upper coil; -inf. = lower coil.





3D radiography



“Easy entry” system

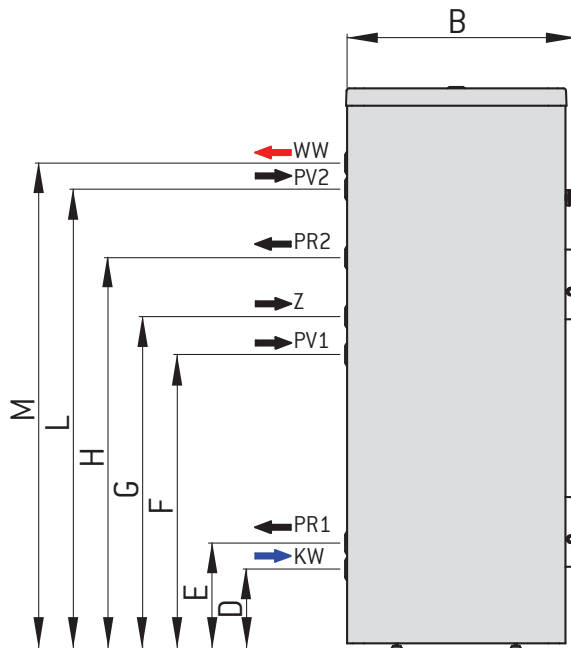
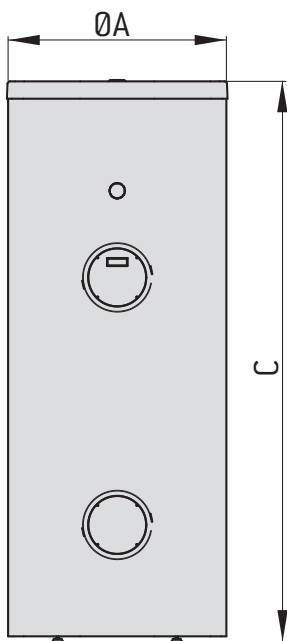
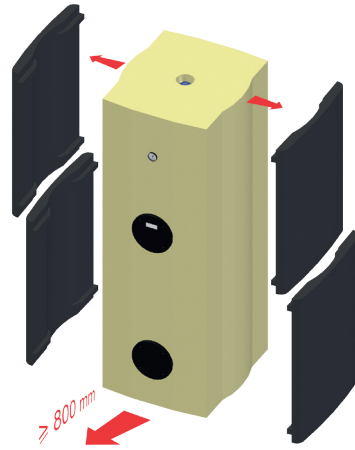

	Max operating press.	Net weight	Hydraulic connections	Heat exchanger connections	Recirculation connections	A	B	C	D	E	F	G	H	L	M
	Mpa	Kg	KW-WW	PV-PR	Z	mm	mm	mm	mm	mm	mm	mm	mm	mm	mm
MEGA BSDX 800	1,0	206	Rp 1½	Rp 1½	Rp 1½	880	925	1865	320	425	985	1090	1178	1478	1580
MEGA BSDX 1000	1,0	237	Rp 1½	Rp 1½	Rp 1½	880	925	2245	320	425	1187	1340	1578	1855	1960



# BSD

INDIRECT CYLINDERS  
FREE STANDING  
INDIRECT HEATING  
LT 200 300 400 500 600

LIKE INDIRECT CYLINDERS / Doble Coil



## The Free Standing for large production

Double coil “free standing” storage indirect cylinders are of the indirect heating variety. They facilitate easy and abundant generation of hot water for all types of use. They may be connected to centralized systems, forced circulation solar heating plants and equipped with additional integration systems. Suitable for industrial and collective use.

Steel tank, glass-lined using the flowcoating method (850 °C).

Front inspection hatch Ø 134 mm.

Anti-corrosion anode of magnesium.

Double coil optimized for maximum heat exchange and reduced limescale formation.

Three sensor sheaths (Tr) installed in the rear section.

Hydraulic connections installed in the rear section.

Recirculation connection.

Insulation in foam polyurethane (PU) of elevated thickness without CFCs and HCFCs.

Outer cover in coloured plastic material (PVC).

Adjustable feet for floor support.

Storage water temperature indicator.

Integration kits available for use of spiroidal exchangers in tinned copper or copper heating elements up to 5 kW and in stainless steel incoloy 800 up to 10 kW with mono and three-phase connections.

**Accessories on page 48**

	Capacity	Coil position	Exchange surface	Power (Δt 35k)*	D.H.W. production (Δt 35k)*	Heating time (Δt 35k)*	Pressure loss	Primary flow rate	Insulation thickness	Heat loss 65°C	Max operating temp.
	l	top./bot.	m <sup>2</sup>	kW	l/h	min	mbar	m <sup>3</sup> /h	mm	kWh / 24 h	°C
BSD 200	200	top	0,50	22	541	23	119	2,0	≥ 50	2,00	95
		bottom	0,70	25,5	627	21	182				
BSD 300	300	top	0,90	31,5	774	24	100	3,0	≥ 50	2,40	95
		bottom	1,40	44	1081	18	138				
BSD 400	400	top	0,90	31,5	774	33	100	3,0	≥ 50	2,80	95
		bottom	1,70	55	1351	19	180				
BSD 500	500	top	0,90	31,5	774	41	100	3,0	≥ 50	3,30	95
		bottom	2,10	63	1543	20	223				
BSD 600	600	top	1,00	34	835	45	64	3,0	≥ 50	3,60	95
		bottom	2,50	68	1671	23	73				

Note: \*Primary temperature 80°C / Secondary 10 /45°C / Primary flow rate indicated in the table - D.H.W. = domestic hot water.

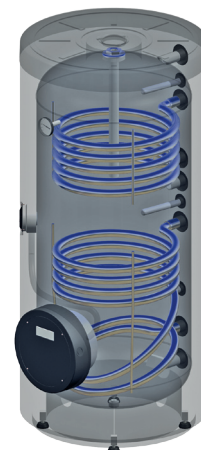
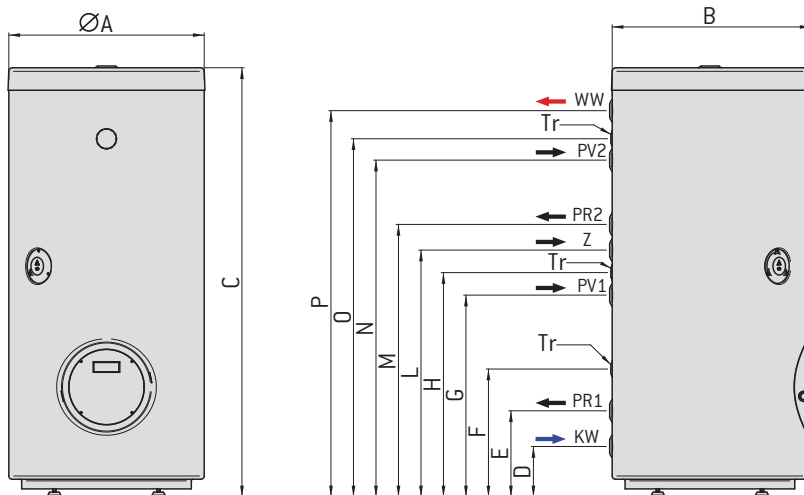
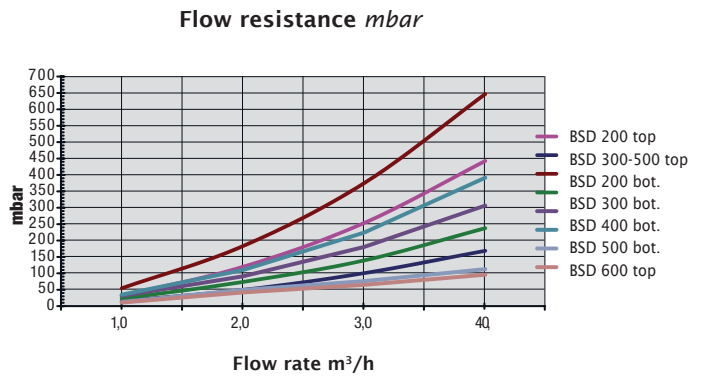
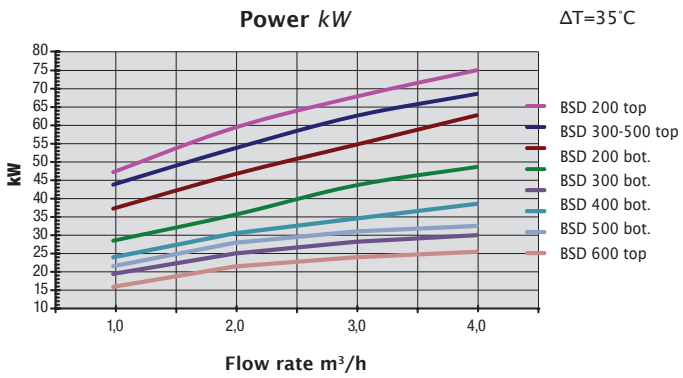

3D radiography

	Max operating press.	Net weight	Hydraulic connections	Heat exchanger connections	Recirculation connections	Number of sensors	A	B	C	D	E	F	G	H	L	M	N	O	P
	Mpa	Kg	KW-WW	PV-PR	Z	Tr	mm	mm	mm	mm	mm	mm	mm	mm	mm	mm	mm	mm	mm
BSD 200	1,0	61	Rp ¾	Rp ¾	Rp ¾	3	610	620	1329	150	261	336	581	661	747	841	1041	1108	1195
BSD 300	1,0	105	Rp 1	Rp 1	Rp 1	3	650	675	1560	148	288	378	693	773	859	956	1225	1292	1408
BSD 400	1,0	133	Rp 1	Rp 1	Rp 1	3	750	775	1553	162	322	402	722	800	879	977	1177	1259	1387
BSD 500	1,0	154	Rp 1	Rp 1	Rp 1	3	750	775	1818	162	322	437	872	972	1072	1172	1372	1457	1652
BSD 600	1,0	234	Rp 1	Rp 1½	Rp 1	3	808	833	1749	123	330	435	945	1035	1110	1200	1452	1527	1658



# MEGA BSD

INDIRECT CYLINDER  
FREE STANDING  
INDIRECT HEATING  
LT 800 1000

LIKE INDIRECT CYLINDERS / Doble Coil



## The Free Standing for very large production

“Free Standing Two high storage” double fixed coil floor-standing storage indirect cylinders are designed to meet the new expectations of the market as to durability, exchange power and great storage.

To this end, this new high-capacity product line was introduced, providing maximum quality and durability owing to the use of special materials and sophisticated technological solutions.

The guarantee of durability in time is further extended by means of a modern “glass-lining” treatment over the tank.

The insulation layer is manufactured by means of a new system that combines the technology of the injected polyurethane (PU) with the flexibility of NEOPOR (EPS). This solution allows the installer to have a “plug and play” product and, in case of need, it is an easy solution for making the product pass through openings whose width equals 800 mm.

This system allows a trouble-free disassembly and re-assembly of the insulation layer for an easier installation in boiler rooms.

The two big front hatchways characterise the line of these products and make them flexible and suitable for several combinations of electrical powers up to maximum 20 kW. The electrical components are supplied apart in handy sin-

gleand three-phase KITS with Incoloy 800 stainless steel heating elements with powers up to 10 kW or made of copper up to 5 kW. Furthermore, you can equip the tank with spiroid exchangers, if any, which can be installed in the hatchways.

They are recommended for 3D radiography.

Steel tank, glass-lined using the flowcoating method (850 °C).

Double Ø 134 mm front hatchway for electrical Kit assembly and inspection.

Ø 134 mm top bottom-flange complete with counter-flange.

Streamlined double coil for the maximum heat exchange process and to reduce the formation of limescale.

Very thick expanded polyurethane (PU) / (EPS) insulation layer. “Easy entry” system.

External coloured plastic coating.

Adjustable feet for floor standing.

Stored water temperature indicator.

They are available in electrical integration kits with the use of Incoloy 800 stainless steel heating elements up to 10 kW with single- and three-phase connections.

**Accessories on page 48**

	Capacity	Coil position	Exchange surface	Power (Δt 35k)*	D.H.W. production (Δt 35k)*	Heating time (Δt 35k)*	Primary flow rate	Insulation thickness	Max operating temp.
	l	sup./inf.	m <sup>2</sup>	kW	l/h	min	m <sup>3</sup> /h	mm	°C
MEGA BSD 800	800	superiore	1,20	40	983	52	3,0	≥ 100	95
		inferiore	3,00	88	2162	24			
MEGA BSD 1000	1000	superiore	1,50	48	1179	54	3,0	≥ 100	95
		inferiore	3,50	100	2457	26			

Note: \*Primary temperature 80°C / Secondary 10 /45°C / Primary flow rate indicated in the table - D.H.W. = domestic hot water.



3D radiography

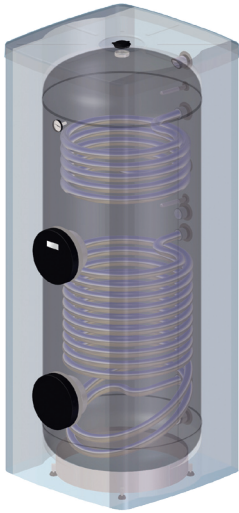

“Easy Entry” system

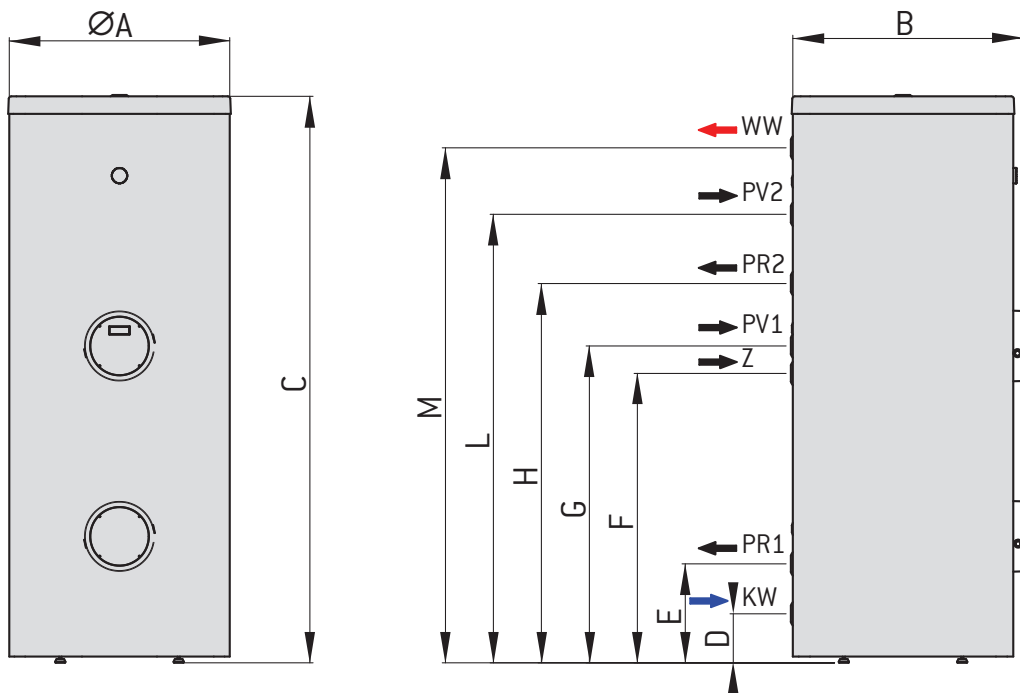
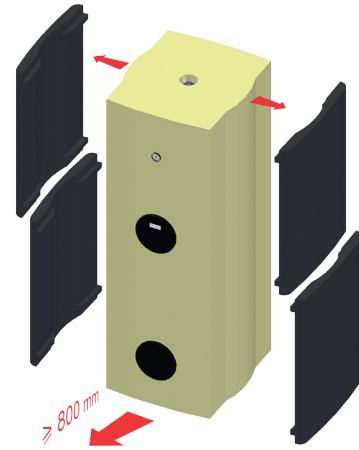

	Max operating press.	Net weight	Hydraulic connections	Heat exchanger connections	Recirculation connections	Number of sensors	A	B	C	D	E	F	G	H	L	M
	Mpa	Kg	KW-WW	PV-PR	Z	Tr	mm	mm	mm	mm	mm	mm	mm	mm	mm	mm
MEGA BSD 800	1,0	292	Rp 1 ¼	Rp 1 ¼	Rp 1 ¼	3	880	925	1865	191	371	1071	971	1251	1461	1676
MEGA BSD 1000	1,0	323	Rp 1 ¼	Rp 1 ¼	Rp 1 ¼	3	880	925	2245	191	3710	1231	1121	1431	1831	2056

LIKE INDIRECT CYLINDERS



# ACCESSORIES & KITS FOR INDIRECT CYLINDER

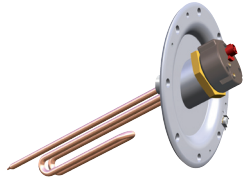

## BSC, BSS, BSD, MEGA BSS, MEGA BSD

### 2.0 KW 230 V~ 1" SINGLE-PHASE ELECTRICAL KIT

formed by: counter-flange with 1" sleeve, gasket, copper armoured heating element and thermostat

### 3.0 KW 230 V~ 1" SINGLE-PHASE ELECTRICAL KIT

formed by: counter-flange with 1" sleeve, gasket, copper armoured heating element and thermostat

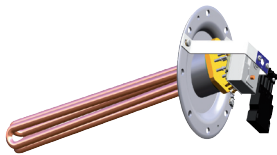

### 3.0 KW 400/3 V~ 2" THREE-PHASE ELECTRICAL KIT

formed by: counter-flange with 2" sleeve, gasket, copper armoured heating element, thermostat equipped with brackets and connectors

### 4.0 KW 400/3 V~ 2" THREE-PHASE ELECTRICAL KIT

formed by: counter-flange with 2" sleeve, gasket, copper armoured heating element, thermostat equipped with brackets and connectors

### 5.0 KW 400/3 V~ 2" THREE-PHASE ELECTRICAL KIT

formed by: counter-flange with 2" sleeve, gasket, copper armoured heating element, thermostat equipped with brackets and connectors

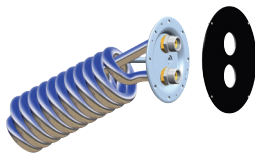

### SPIROID EXCHANGER KIT 1.0 SQM

formed by: counter-flange, finned coil made of tinned copper 1 sqm; gasket, union set, round grill, fastening screws and nuts FOR ALL SERIES

### SPIROID EXCHANGER KIT 1.8 SQM

ONLY FOR SERIES 400-500-600-800-1000

formed by: counter-flange, finned coil made of tinned copper 1.8 sqm; gasket, union set, round grill, fastening screws and nuts.

### PRIORITY KIT

formed by: thermostat in exchange, two-contact relay, bipolar switch, wired cap

## BSS/BSSX, BSD/BSDX, MEGA BSSX, MEGA BSDX

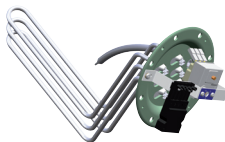

### 3.0÷6.0 KW 400/3V~ THREE-PHASE INOX ELECTRICAL KIT

formed by: counter-flange, gasket, three-element Incoloy 800 stainless steel heating element, thermostat and support bracket **RECOMMENDED FOR SERIES 160-200-300**

### 4.0÷8.0 KW 400/3 V~ THREE-PHASE INOX ELECTRICAL KIT

formed by: counter-flange, gasket, three-element Incoloy 800 stainless steel heating element, thermostat and support bracket. **RECOMMENDED FOR SERIES 400-500-600-800-1000**

### 5.0÷8.0 KW 400/3 V~ THREE-PHASE INOX ELECTRICAL KIT

formed by: counter-flange, gasket, three-element Incoloy 800 stainless steel heating element, thermostat and support bracket. **RECOMMENDED FOR SERIES 400-500-600-800-1000**

## BMI



### 1.2 KW 230 V~ ELECTRICAL KIT - FOR SERIES 80-100

formed by: copper armoured heating element, thermostat and wired cap, only for wall-mount vertical or horizontal installations

### 1.5 KW 230 V~ ELECTRICAL KIT - FOR SERIES 115

formed by: copper armoured heating element, thermostat and wired cap only for wall-mount vertical or horizontal installations

### 2.0 KW 230 V~ ELECTRICAL KIT - FOR SERIES 150-200

FEET FOR FLOOR STANDING. FOR SERIES 80-100-115-150-200



# INERTIAL PUFFERS

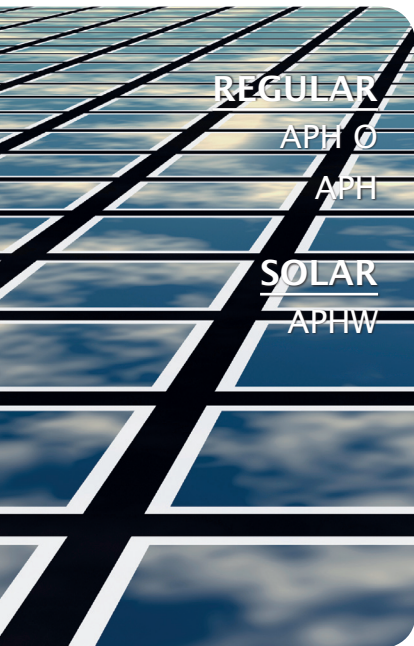

## THE RANGE

The range of inertial puffers is formed by heating water storages with the opportunity to combine a fixed coil exchanger, too.

They allow storing heating water generated by discontinuous heating systems; therefore, they allow a considerable recovery and/or exploitation of thermal energy that would be unused or even wasted.

From this point of view, they well integrate into energy saving systems, and become the “thermal source” of the energy system within heating and domestic hot water generation systems.

Owing to their peculiarity, they are usually connected to systems that generate heat in a discontinuous way, such as for example wood-fired boilers, solid-fuel stacks or stoves, or rather installed in low water systems to limit the interventions of the burners.

As for the version with fixed exchanger, besides what is said above, it is used for maximum exploitation of “thermal solar systems” or with “heat pump”.

The capacity field covered by this range is included between 200 and 1,000 litres.

Product lines cover the standard “PH O”, “PH” with front hatchway, solar “PH W” with fixed exchanger and front hatchway up to solar “TTS” with the production of domestic hot water.

All products are equipped with fittings for electric integrations by means of specific kits from 3.0 kW to 12.0 kW, while the products having the hatchway can install further electric kits from 2.0 to 10.0 kW, or kits with tinned copper spiroid exchangers.

## THERMAL INSULATION LAYER

It is manufactured with very thick and high-density polyurethane foam to assure excellent thermal insulation.

- Rigid polyurethane (PU) for 200 ÷ 600 Lt. models.
- Flexible polyurethane (PU) for 800 ÷ 1.000 Lt. models.

## RECYCLING

800 and 1,000l puffers have been designed so that they can be completely disassembled at the end of their life cycle, in a way to allow their correct recycling and/or the disposal of their components.

## RESPECT OF THE NATURAL ENVIRONMENT

LIKE undertakes streamlining the industrial activities and the respect of the natural environment. In order to reduce the impact over the environment to the minimum, LIKE removed the hydrofluorocarbons (CFC-HCFC) from the insulation layer, and always pays great attention to the recyclability of the components.



# APH

INERTIAL PUFFER  
LT 200 300 400 500  
600 800 1000

## An essential reserve



“PH” inertial puffers are characterised by the ability to store heating water that comes from several sources, mainly discontinuous ones. In addition, they are arranged for the installation of an electric integration, which is supplied by means of specific kits up to 12 kW.

- Raw carbon steel internal tank.
- Hydraulic fittings to be found on the rear.
- Probe sheaths (Tr) to be found on the rear.
- CFC and HCFC-free very thick rigid expanded polyurethane (PU) insulation layer. “Easy entry” system plus (EPS) for series 800/1000.
- External coloured plastic (PVC) coating.
- Adjustable feet for floor standing.
- Arrangement of electric heating element with front 1” sleeve.
- Available electrical KIT with Incoloy 825 stainless steel heating elements on a 1” fitting with powers from 3 to 12 kW and three-phase connection.
- A KIT is available in the hatchway for the use of tinned copper spiroid exchangers or a copper heat element up to 5 kW or Incoloy 800 stainless steel heating element up to 10 kW with single- and three-phase connections.

LIKE INERTIAL PUFFERS

### APH O WITHOUT HATCHWAY LT 200 - 300 - 400 - 500 - 600 - 800 - 1000

	Capacity	Insulation layer thickness	Max. working temperature	Max. working pressure	Net weight	Heating element fitting	Hydraulic fittings	Fitting on upper bottom	Number of probes/diameter
	l	mm	°C	Mpa	kg	r	m, ri, rc, sc, ric		nr/mm
APH O 200	200	>50 PU	95	0,3	51	Rp 1 ½	Rp ¾	Rp 2"	3 /Ø16
APH O 300	300	>50 PU	95	0,3	75	Rp 1 ½	Rp 1	Rp 2"	3 /Ø16
APH O 400	400	>50 PU	95	0,3	97	Rp 1 ½	Rp 1	Rp 2"	3 /Ø16
APH O 500	500	>50 PU	95	0,3	113	Rp 1 ½	Rp 1	Rp 2"	3 /Ø16
APH O 600	600	>50 PU	95	0,3	174	Rp 1 ½	Rp 1	Rp 2"	3 /Ø16
APH O 800	800	>50	95	0,3	140	Rp 1 ½	Rp 1¼	Rp 2"	3 /Ø16
APH O 1000	1000	>50	95	0,3	164	Rp 1 ½	Rp 1¼	Rp 2"	3 /Ø16

### APH WITH HATCHWAY LT 200 - 300 - 400 - 500 - 600 - 800 - 1000

	Capacity	Insulation layer thickness	Max. working temperature	Max. working pressure	Net weight	Heating element fitting	Hydraulic fittings	Fitting on upper bottom	Number of probes/diameter
	l	mm	°C	Mpa	Kg	R	M, Ri, RC, SC, Ric		Nr/mm
APH 200	200	>50 PU	95	0,3	53	Rp 1 ½	Rp ¾	Rp 2"	3 /Ø16
APH 300	300	>50 PU	95	0,3	77	Rp 1 ½	Rp 1	Rp 2"	3 /Ø16
APH 400	400	>50 PU	95	0,3	99	Rp 1 ½	Rp 1	Rp 2"	3 /Ø16
APH 500	500	>50 PU	95	0,3	115	Rp 1 ½	Rp 1	Rp 2"	3 /Ø16
APH 600	600	>50 PU	95	0,3	176	Rp 1 ½	Rp 1	Rp 2"	3 /Ø16
APH 800	800	>50	95	0,3	143	Rp 1 ½	Rp 1¼	Rp 2"	3 /Ø16
APH 1000	1000	>50	95	0,3	167	Rp 1 ½	Rp 1¼	Rp 2"	3 /Ø16

### APHW WITH HATCHWAY AND SPIROID EXCHANGERS LT 800 - 1000

	Capacity	Exchange surface	Power (Δt 35)*	D.H.W. production (Δt 35 k)*	Heating time (Δt 35k)	Insulation layer thickness	Max. working temp.	Max. working pressure	Net weight	Heating element fitting	Hydraulic fittings	Exchanger fittings	Fitting on upper bottom	Number of probes/diameter
	l	m²	kW	l/h	min	mm	°C	Mpa	Kg	R	M, Ri, RC, SC, Ric	SCA		Nr/mm
APHW 800	800	3,00	88	2162	24	>50	95	0,3	205	Rp 1 ½	Rp 1¼	Rp 1¼	Rp 2"	3 /Ø16
APHW 1000	1000	3,50	100	2457	26	>50	95	0,3	241	Rp 1 ½	Rp 1¼	Rp 1¼	Rp 2"	3 /Ø16

### APH O 200÷600

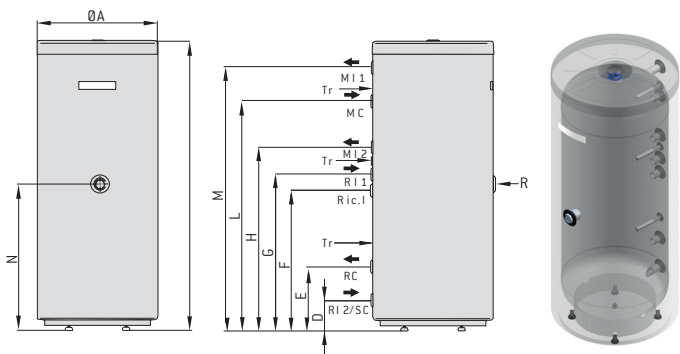

### APH O 800÷1000

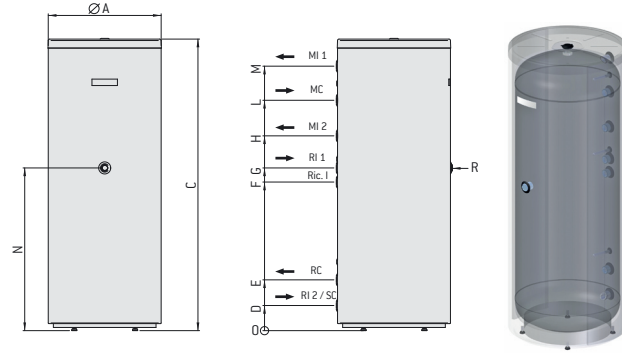

	A	C	D	E	F	G	H	L	M	N
	mm	mm	mm	mm	mm	mm	mm	mm	mm	mm
APH O 200	610	1329	150	261	621	761	841	1041	1195	735
APH O 300	650	1560	156	336	751	841	984	1236	1416	785
APH O 400	755	1553	161	321	721	878	976	1176	1385	839
APH O 500	755	1818	161	364	914	1056	1131	1381	1651	906
APH O 600	810	1749	123	330	930	1075	1150	1400	1658	891
APH O 800	880	1865	191	371	971	1071	1251	1461	1676	1123
APH O 1000	880	2245	191	371	1121	1231	1431	1831	2056	1268

### APH 200÷600

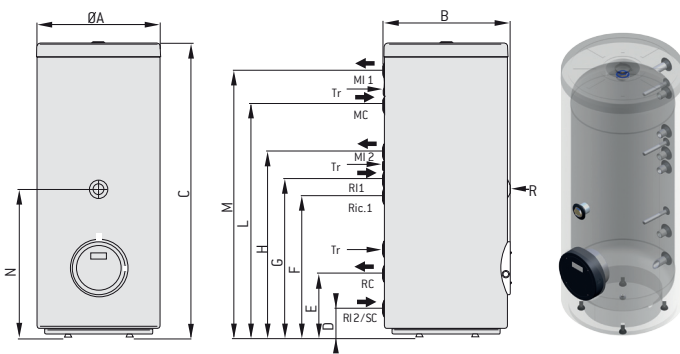

### APH 800÷1000

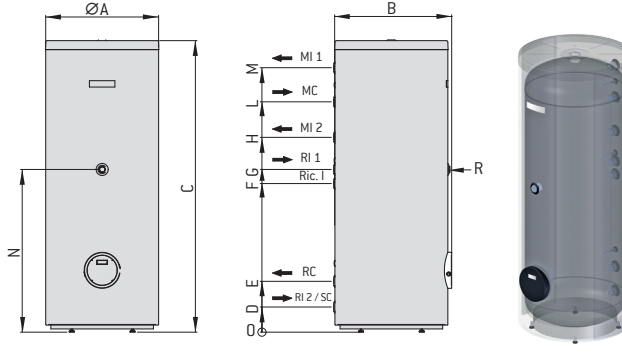

	A	B	C	D	E	F	G	H	L	M	N
	mm	mm	mm	mm	mm	mm	mm	mm	mm	mm	mm
APH 200	610	627	1329	150	261	621	761	841	1041	1195	735
APH 300	650	674	1560	156	336	751	841	984	1236	1416	785
APH 400	755	775	1553	161	321	721	878	976	1176	1385	839
APH 500	755	775	1818	161	364	914	1056	1131	1381	1651	906
APH 600	810	827	1749	123	330	930	1075	1150	1400	1658	891
APH 800	880	910	1865	191	371	790	1071	1251	1361	1676	1123
APH 1000	880	910	2245	191	371	880	1231	1431	1831	2056	1268

### APHW 800÷1000

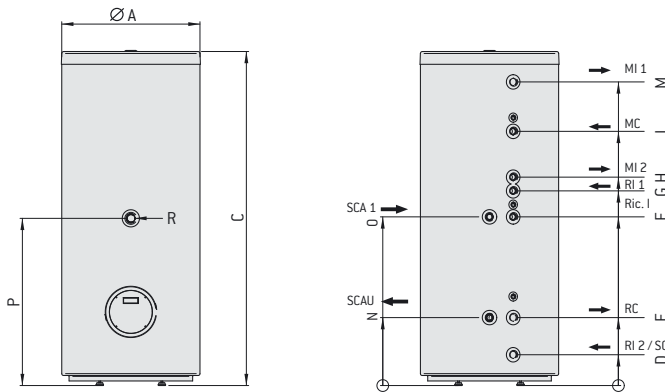

	A	B	C	D	E	F	G	H	L	M	N	O
	mm	mm	mm	mm	mm	mm	mm	mm	mm	mm	mm	mm
APHW 800	880	910	1865	191	371	971	1071	1251	1461	1676	371	971
APHW 1000	880	910	2245	191	371	1121	1231	1431	1831	2056	371	1121



LIKE INERTIAL PUFFERS



# TANK in TANK



The “Tank in Tank” range of solar puffers with the production of domestic hot water is an integrated system formed by a thermal storage for heating (puffer) and a glass-lined tank, which is dipped inside the puffer, for the production of domestic hot water.

The insulation layer is manufactured by means of a new system that combines the technology of the injected polyurethane (PU) with the flexibility of NEOPOR (EPS) (only for series 750-900).

This solution allows the installer to have a “plug and play” product and, in case of need, it is an easy solution for making the product pass through openings whose width equals 800 mm.

This system allows a trouble-free disassembly and re-assembly of the insulation layer for an easier installation in boiler rooms.

Owing to their peculiarity, they are usually connected to systems that generate heat in a discontinuous way, such as for example wood-fired boilers, solid-fuel stacks or stoves, or rather installed in low water systems to limit the interventions of the burners.

The fixed exchanger to be found in the system is used for maximum exploitation of “thermal solar systems” or with “heat pump”.



### Saving and daily wellness

#### 3D radiography

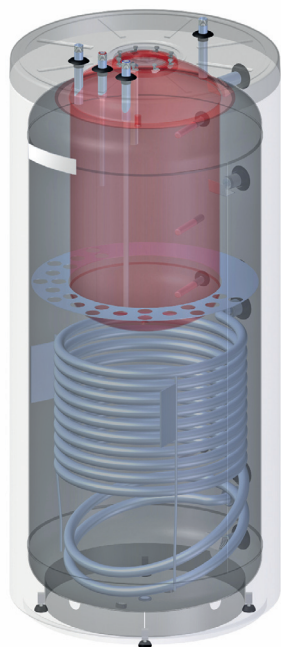

Raw carbon steel internal tank (puffer).  
Carbon steel fixed exchanger welded to the puffer.

Perforated diaphragm fastened to the puffer for improved internal lamination.

Domestic hot water steel tank, glass-lined using the flow-coating method (850°C).

Corrosion-proof magnesium anode (domestic hot water tank).

Hydraulic fittings to be found on the rear.

Probe sheaths (Tr) to be found on the rear.

CFC and HCFC-free very thick expanded polyurethane insulation layer.

“Easy entry” system for series 750 and 900.

External coloured plastic (PVC) coating.

Adjustable feet for floor standing.

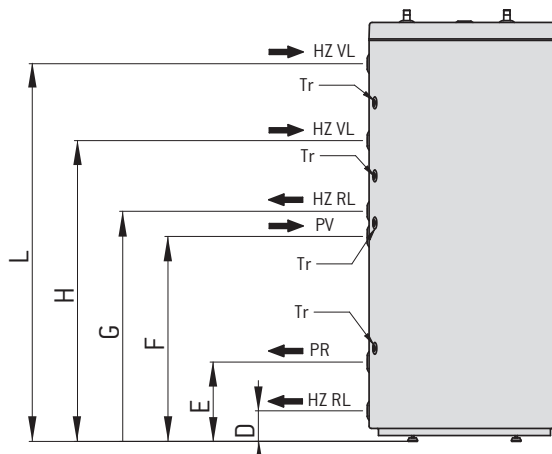
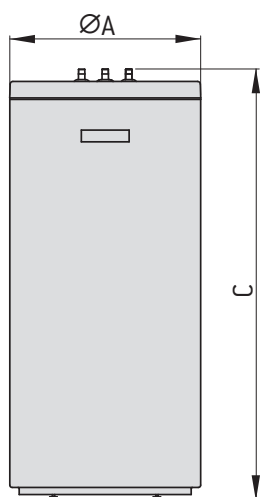
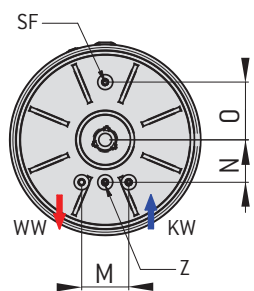

LIKE SOLAR PUFFERS TANK IN TANK

	Capacity	Heating capacity	D.H.W. capacity	Exchange surface	Power ( $\Delta t$ 35)*	Insulation layer thickness	Max. working temperature	Heating working max. pressure	DHW working max. pressure	Net weight
	l	l	l	m <sup>2</sup>	Kw	mm	°C	Mpa	Mpa	kg
TTL 600/130	600	470	130	2,10	81	≥ 50	95	0,3	0,8	190
TTL 750/180	750	570	180	2,50	91	≥ 50	95	0,3	0,8	220
TTL 900/230	900	670	230	3,00	105	≥ 50	95	0,3	0,8	260

	Exchanger fittings	Vent fitting	DHW fittings	Heating fitting	Number of probes/diameter	A	C	D	E	F	G	H	L	M	N	O
	PV-PR	SF	WW, Z, KW	HZ VL, HZ RL	Nr/mm	mm	mm	mm	mm	mm	mm	mm	mm	mm	mm	mm
TTL 600/130	Rp 1 ¼	Rp ¾	Rp ¾	Rp 1	4/Ø16	808	1831	130	337	870	977	1277	1603	200	180	245
TTL 750/180	Rp 1 ¼	Rp ¾	Rp ¾	Rp 1 ¼	4/Ø16	880	1865	191	371	971	1251	1461	1676	200	180	245
TTL 900/230	Rp 1 ¼	Rp ¾	Rp ¾	Rp 1 ¼	4/Ø16	880	2245	191	371	1121	1431	1831	2056	200	180	245



# HEAT PUMPS

## STAND ALONE

SINGLE COIL  
DOUBLE COIL



## ADVANTAGES

The arguments in favour of the use of the heat pump may be summarized as follows:

- absence of a deposit for the fuel (tank) and a flue;
- absence of systems of collection and discharge for waste products;
- absence of safety measures linked to the use of combustible materials;
- use of renewable energy;
- no emission of fumes or CO<sub>2</sub> or other pollutant substances, the only "waste" is the heat;
- maintenance costs practically absent;
- no dependence on fluctuations in the market for fossil fuel energy;
- Value added to one's home.

## USE

The space necessary for installation should have a volume of 20m<sup>3</sup> and a minimum floor surface area of 6 m<sup>2</sup>.

The ambient temperature for optimum functioning should vary between +6°C and +32°C.

The heat pump should be installed only in spaces protected from the cold.

The temperature regulator provides an anti-freeze position (\*), in which the water in the accumulator is maintained at a temperature of 20°C, which in cases of lengthy absences protects the connected piping as well as the accumulator.

During the cooling process condensation may form depending on temperature or air humidity. The condensation is collected in an appropriate basin and is conveyed by a flexible pipe onto the rear section of the appliance.

A kit is also provided which permits the conveyance of the air to areas other than those surrounding the installation.

## GENERAL PRINCIPLES OF FUNCTIONING

The HEAT PUMP generates sanitary hot water using the heat present in the area where it is installed. The appliance consists of a closed circuit crossed by a special refrigerant fluid which assumes a liquid or gas state, depending on the temperature and pressure conditions where one is.

This closed circuit consists of:

- A Compressor
- A Condenser
- An Expansion or Lamination valve
- An Evaporator

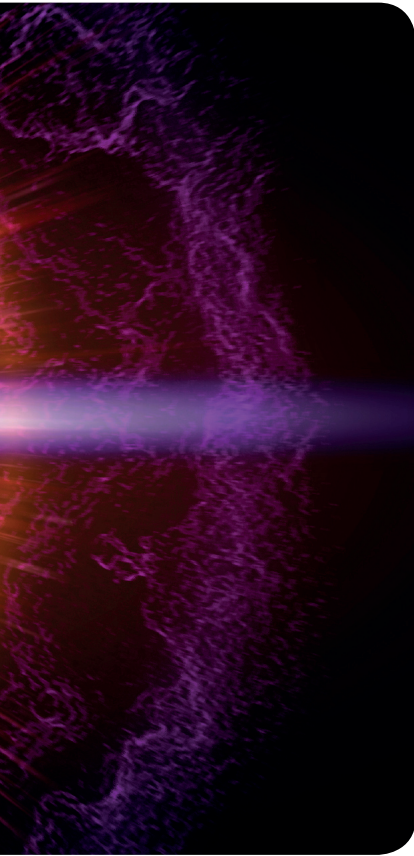

## THE RANGE

One of the technologies to which LIKE increasingly applies itself is the use of alternative sources of energy, in particular heating of water by a HEAT PUMP.

A HEAT PUMP is capable of transferring environmental heat to the sanitary water contained in the tank; in fact the basic functioning principle of the heat pump is that of a thermodynamic cycle opposite to that of the fridge.

The efficiency of a HEAT PUMP is represented by the coefficient of performance C.O.P., understood as the relation between energy delivered to the body to be heated and the electric energy consumed. C.O.P. values for efficient systems are equivalent to 3: this signifies that for each kWh of electric energy consumed, the heat pump will deliver 3kW of thermal energy to heat the water.

The heat pump is a modern solution, eco-friendly, convenient and economical to use.

*The heat pump comprises a closed circuit made up of a compressor, a condenser, a lamination valve and an evaporator through which the heat transfer fluid flows. The thermodynamic cycle the fluid experiences consists in an adiabatic compression, a condensation phase, an expansion phase and also evaporation. During compression, the pressure and temperature of the fluid rise, during the second stage the fluid flows through a heat exchanger (condenser) where it comes into contact with domestic water, to which it yields heat. During the third stage, the fluid flows through an expansion valve (lamination process) and its pressure and temperature consequently drop. During the last stage, referred to as evaporation, the fluid switches from its liquid state to gas: the coolant is at very low temperatures, which enable it to absorb heat from the external heat transfer fluid. So during the operation of the heat pump, the following occurs: electricity is consumed in the compressor, heat is absorbed from the external environment (evaporator) and heat is yielded in the condenser to the liquid that needs to be heated. The advantage of a heat pump lies in the fact that more energy is supplied in the form of heat than the electricity required for its operation.*

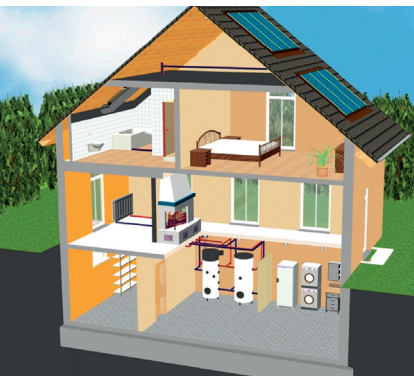

## HEAT EXCHANGE PROCESS

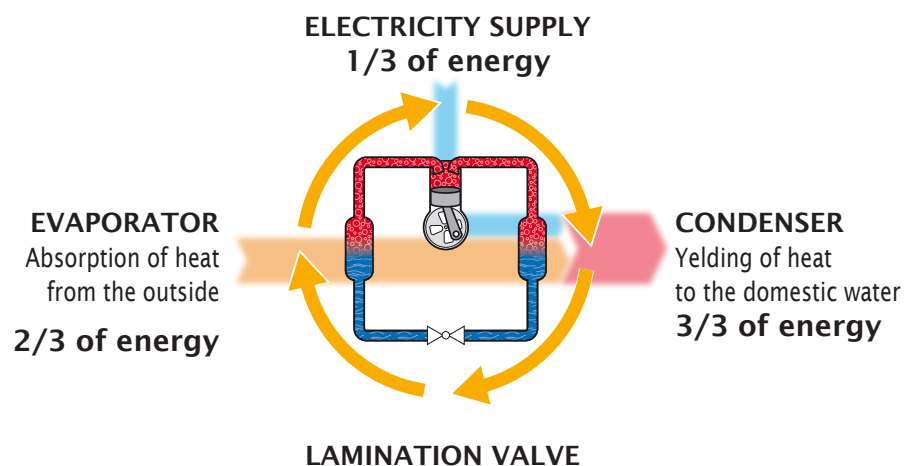



# HEAT PUMPS

STAND ALONE  
WATER HEATER  
LT 180 300

## Multipurpose, completely equipped

LIKE HEAT PUMPS / Renewable Energy



System for heating of sanitary water with air-water heat pump.

The system provides for the use of renewable energy and possible integration with other forms of energy such as electric energy. Suitable for domestic use.

Steel boiler enamel glazed with flow coating method (850°C).

Frontal inspection hatch Ø 134 mm integrated with condenser in tinned copper.

Anti-corrosion anode of magnesium.

Hydraulic connections inserted in the rear section.

Insulation in foam polyurethane (PU) of elevated thickness without CFCs and HCFCs.

Outer cover in plastic material (PVC).

Adjustable feet for floor support.

Eco-friendly Gas R 134a.

Electric heating element of 1,5 kW 230V~.

Control panel complete with luminous switch for control of heat pump and heating element, thermostat regulation, thermometer and signal displays.

Safety measures for high and low pressure.

Compressor DANFOSS for maximum silent functioning.

Axial fan EBM of 650 m<sup>3</sup>/h.

	Capacity	Power supply	Refrigerant fluid Medium charge	Absorption (heat pump only)*	Maximum nomi- nal absorption	Power yield (heat pump only)*	Electric heating element (integration)	Maximum power yield	Hot water setting range	Range of use
	l	V/Hz/A	-/Kg	kW	kW	kW	kW	kW	°C	°C
HP 180	180	230/50/16	R134a/0,85	0,62	2,12	1,91	1,50	3,41	29÷56	8÷35
HP 300	300	230/50/16	R134a/0,85	0,62	2,12	1,98	1,50	3,48	29÷56	8÷35

	Maximum noise level	Lower/upper surface coil	Power (Δt 35k)** lower/upper	Primary flow rate	Max. operating temp.	Max. operating press.	Net weight	Hydraulic connections	Heat exchanger connections	Recircula- tion connections	Number of sensors
	dB (A)	m <sup>2</sup>	kW	m <sup>3</sup> /h	°C	Mpa	Kg	KW-WW	PV-PR	Z	Tr
HP 180	61	-/-	-	-	95	1,0	95	Rp 1	-	Rp 1	-
HP 300	61	-/-	-	-	95	1,0	109	Rp 1	-	Rp 1	-

Note: \*\*Primary temperature 80°C, Secondary 10/45 °C



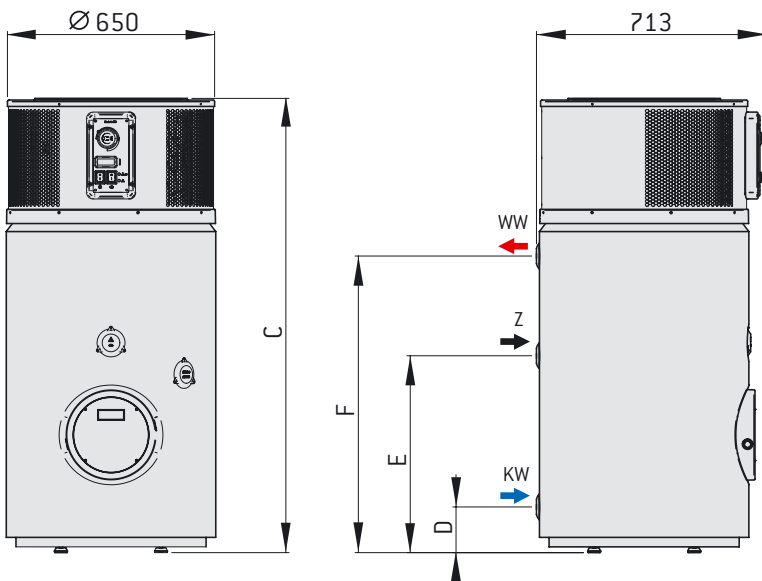
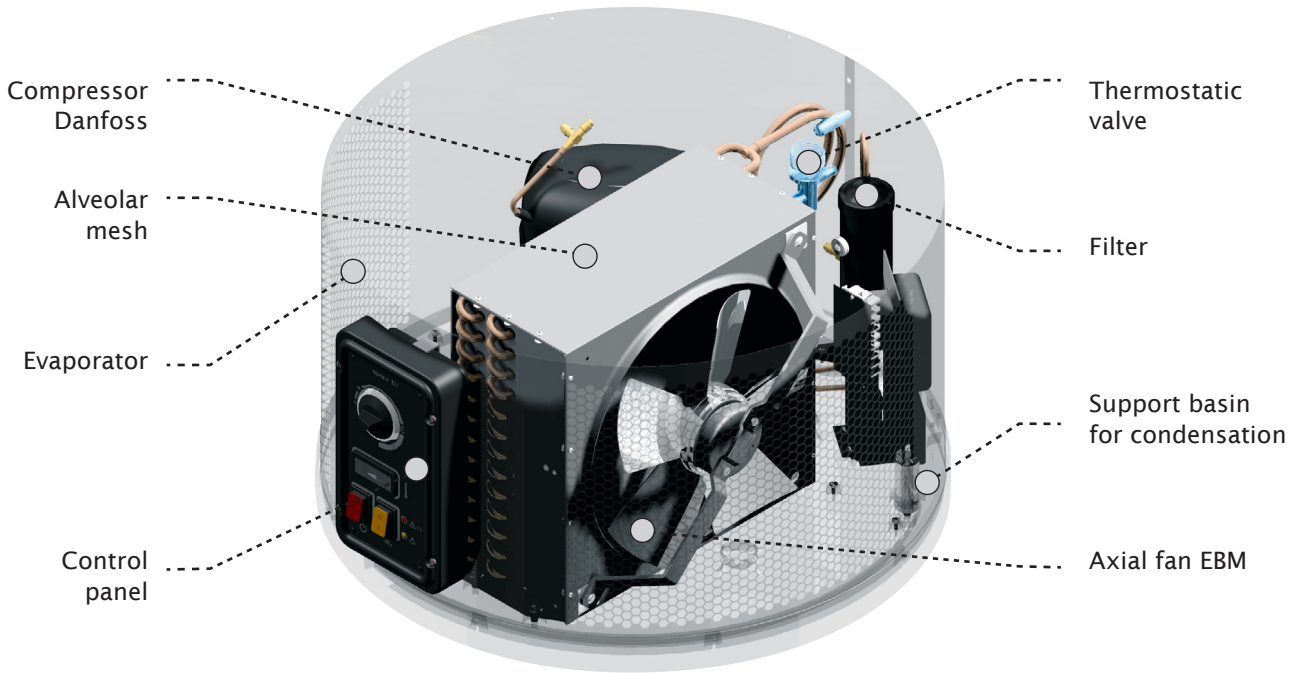

Data in accordance with EN 255-3 (WPZ B-002-04-07 Wärmepumpentestzentrum NTB - FWS CH-Buchs)\*

	Coefficient of pressure	Maximum quantity of single withdrawal at 40°C V <sub>max</sub>	Effective power consumption P <sub>es</sub>	Effective absorption energy W <sub>eh</sub>	Heating time t <sub>h</sub>	C	D	E	F
	COP <sub>t</sub>	I	W	kWh	h:min	mm	mm	mm	mm
HP 180	3,1	283	35,5	-	4:56	1412	142	612	922
HP 300	3,2	448	44,1	-	7:57	1852	142	912	1362

Note: \*Ambient air temperature 15°C, humidity 71%, sanitary water 15°C, Temperature in storage 55°C.



# HEAT PUMPS

FIXED  
AND DOUBLE COIL  
WATER HEATER  
LT 300

## Polifunzionale con dotazione completa

LIKE HEAT PUMPS / Renewable Energy



Domestic water heating system with air-water heat pump. The system envisages the use of renewable energy and the possible integration with other energy sources such as electricity, thermal energy and solar power.

Recommended for domestic and collective use.

Steel tank, glass-lined using the flowcoating method (850 °C).

Ø 134 mm front inspection hatch integrated with tinned copper condenser.

Single coil (for W version) and double coil (for WW version), optimised for maximum heat exchange and minimum limescale build-up.

Sensor fittings, (one for W version) (two for WW version).

Corrosion-proof magnesium anode.

Hydraulic connections located on the rear.

CFC and HCFC-free very thick polyurethane (PU) foam insulation layer.

External plastic (PVC) coating.

Adjustable feet for floor standing.

Environmentally-friendly gas R 134a.

1.5 kW 230V~ electric heating element.

Control panel complete with switch with indicator light for heat pump and heating element operation, regulation thermostat, thermometer and signal indicators.

High and low pressure safety devices.

DANFOSS compressor for super silent operation.

EBM 650 m3/h axial fan.

	Capacity	Power supply	Refrigerant fluid Medium charge	Absorption (heat pump only)*	Maximum nomi- nal absorption	Power yield (heat pump only)*	Electric heating element (integration)	Maximum power yield	Hot water setting range	Range of use
	l	V/Hz/A	-/Kg	kW	kW	kW	kW	kW	°C	°C
HP 300 W	300	230/50/16	R134a/0,85	0,62	2,12	1,91	1,50	3,41	29÷56	8÷35
HP 300 WW	300	230/50/16	R134a/0,85	0,62	2,12	1,91	1,50	3,48	29÷57	8÷35

	Maximum noise level	lower/upper surface coil	Power (Δt 35k)** lower/upper	Primary flow rate	Max. operating temp.	Max. operating press.	Net weight	Hydraulic connections	Heat exchanger connections	Recircula- tion connections	Number of sen- sors	Thermal dispersion 65°
	dB (A)	m <sup>2</sup>	kW	m <sup>3</sup> /h	°C	Mpa	Kg	KW-WW	PV-PR	Z	Tr	kWh / 24 h
HP 300 W	61	1,30/-	37/-	2,50	95	1,0	130	Rp 1	Rp 1	Rp 1	1	2,40
HP 300 WW	61	1,30/0,80	37/26	2,50	95	1,0	145	Rp 1	Rp 1	Rp 1	2	2,40

Note: \*\*Primary temperature 80°C, Secondary 10/45 °C



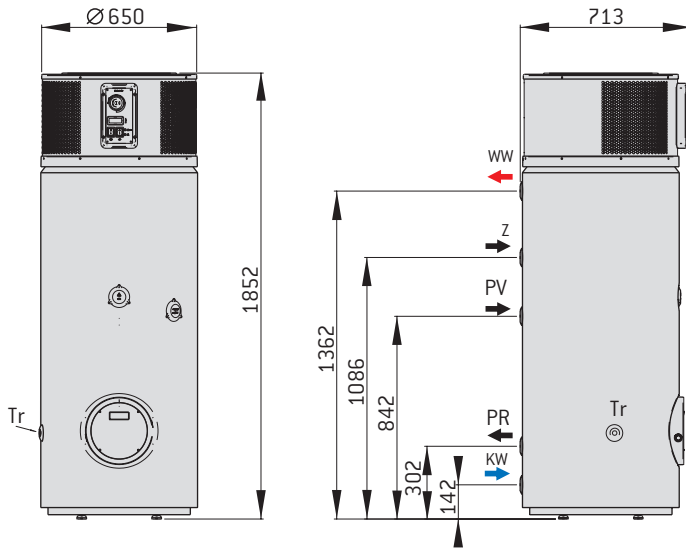

Dimensional diagrams (mm)  
Model HP 300 W



3D Radiography  
HP 300 W

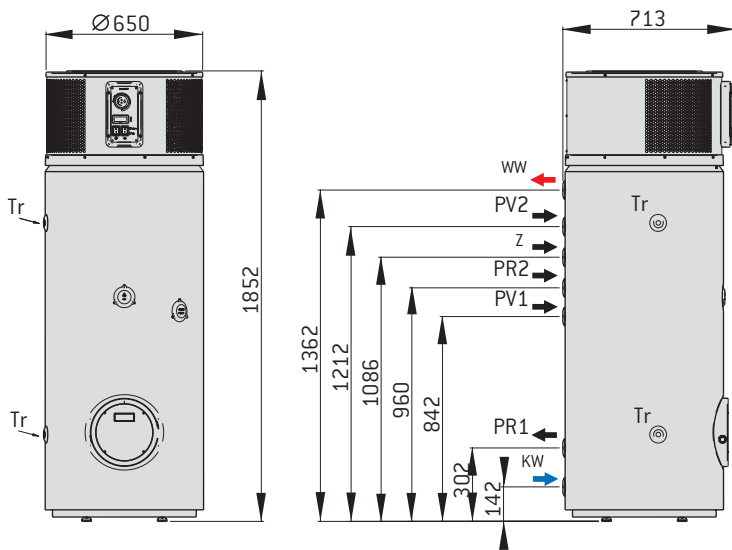

Dimensional diagrams (mm)  
Model HP 300 WW



3D Radiography  
HP 300 WW

Data in accordance with EN 255-3 (WPZ B-002-04-07 Wärmepumpentestzentrum NTB - FWS CH-Buchs)\*

	Coefficient of pressure	Maximum quantity of single withdrawal at 40°C V <sub>max</sub>	Effective power consumption P <sub>es</sub>	Effective absorption energy W <sub>eh</sub>	Heating time t <sub>h</sub>	C	D	E	F
	COP <sub>t</sub>	l	W	kWh	h:min	mm	mm	mm	mm
HP 300 W	3,1	430	55	4,24	8:01	see diagram			
HP 300 WW	3,1	430	55	4,24	8:01	see diagram			

Note: \*Ambient air temperature 15°C, humidity 71%, sanitary water 15°C, Temperature in storage 55°C.



# ACCESSORIES & KITS FOR HEAT PUMPS

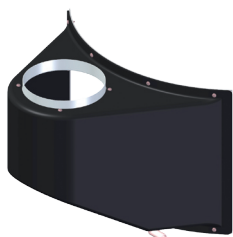

## AIR DELIVERY KIT

The kit includes: black PST air conveyor, conveyor fastening system, aluminium rings for Ø160mm pipe fastening, instructions, package.

## AIR SUCTION KIT

The kit includes: black PST air conveyor, conveyor fastening system, aluminium rings for Ø 160 mm pipe fastening, instructions, package.

### KIT DIAGRAM

SUCTION      DELIVERY

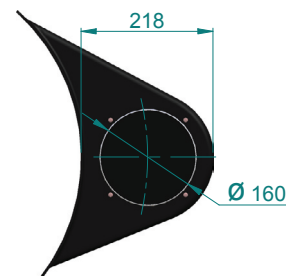
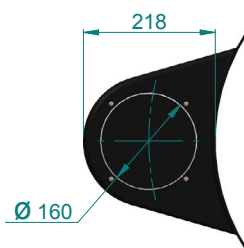
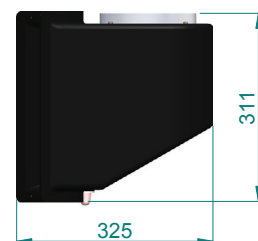
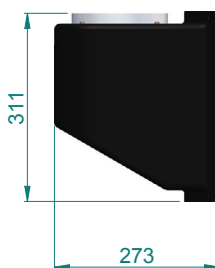

KIT SUCTION

KIT DELIVERY

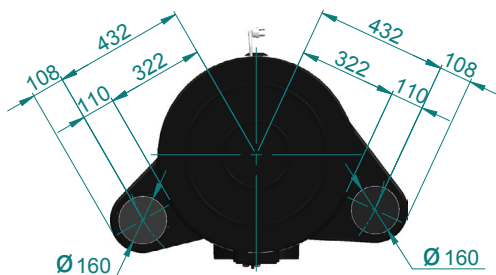



# GENERAL NOTES

All LIKE production is in strict keeping with European and International Directives. Gas appliances are provided for and specifically approved for use of standard fuels.

All LIKE products manufactured at the production unit of S. Maria di Zevio (VR) are designed and produced in keeping with international quality standards ISO 9001/2000 and conform to art. 3.3 of European directive 97/23/EC (PED).

## INSTALLATION AND USE

The products are approved for installation in internal spaces only.

Installation of the products should be carried out and certified exclusively by personnel qualified in accordance with the Law.

It is necessary to install a 'hydraulic safety unit' on all products in conformity with the EN 1487 or equivalent.

Water temperature regulation permits optimization of energy consumption, depending on level of comfort sought. But it is advisable for temperatures of the water in storage not to fall too low, so as to prevent formation of the "legionella" bacterium.

Certain general prevention measures should be adopted to this end:

- Maintain the hot water inside the appliance at a temperature not lower than 50°C;
- Where there has been a prolonged absence, run the water from the taps and showers for a few minutes;
- Keep showers and taps free of scaling.

The guarantee will be void in cases of non-specified uses.

## GUARANTEE

LIKE guarantees proper functioning of its own appliances as described in the guarantee certificates enclosed with that products and always in conformity with the current laws.

## DESCRIPTION OF GOODS

Data included in catalogues, advertisements and price lists of the Company shall be deemed to be approximate only, unless specifically confirmed in writing by the Company. The Company reserves the right to alter the specification of any goods without prior reference to the Purchaser provided that the goods comply in all know respects with the Purchaser's requirements.

## INTERNET WEBSITE

All information and product dossiers as well as news items about the firm are available on the internet at [www.likeonline.it](http://www.likeonline.it)

Easy to consult and navigate, the site presents a complete showcase of LIKE products with the opportunity to download specific documentation available on the site

In the news section the latest innovations are posted, practical information, meetings of the sector for users and professionals. Through the internet, dynamic communication is possible in a way that is modern and fast.





likeonline.it

www.studiocamelot.it

2000-06/08

LIKE it's a brand of:



*Headquarter:*

Via Apollo XI, 1  
37059 S. Maria di Zevio (VR)  
tel. +39 045 6050099 r.a.  
fax +39 045 6050124

*Operational Office:*

Località Oliero di Sotto  
36020 Valstagna (VI)  
Fax Serv. Clienti +39 0424 98627

*Production Units:*

Località Oliero di Sotto  
36020 Valstagna (VI)  
Via Apollo XI, 1  
37059 S. Maria di Zevio (VR)

*Internal boiler protection treatments:*

ZIAC S.p.A.  
Loc. Speranza  
37059 S. Maria di Zevio (VR)

Via C. Grazioli 27/A  
29012 Caorso (PC)